

TROUBLESHOOTING CHART:

Problem	Cause	Solution
1. No discharge	a. No water b. Magnetic valve not functioning c. Excessive water pressure d. Eductor clogged e. Low flow mechanism failure f. Clogged water inlet strainer	a. Open water supply b. Install valve parts kit c. Install regulator if flowing water pressure exceeds 60 PSI d. Clean* or replace e. Install new parts f. Disconnect inlet water line and clean strainer
2. No concentrate draw	a. Clogged foot strainer b. Metering tip or eductor has scale build-up c. Low water pressure d. Discharge tube and/or flooding ring not in place (high flow only) e. Concentrate container empty f. Inlet hose barb not screwed into eductor tightly g. Clogged water inlet strainer h. Selector out of position i. Check valve installed backwards j. Air leak in chemical pick-up tube k. Clear plastic tip installed in inlet hose barb	a. Clean or replace b. Clean (descale)* or replace c. Minimum 25 PSI (with water running) required to operate unit properly d. Push tube firmly onto eductor discharge hose barb, or replace tube if it doesn't have a flooding ring e. Replace with full container f. Tighten, but do not overtighten g. Disconnect inlet water line and clean strainer h. Assure selector is in position desired i. Confirm colored side is pointed toward eductor j. Put clamp on tube or replace tube if brittle k. Replace with colored metering tip
3. Excess concentrate draw	a. Metering tip not in place	a. Press correct tip firmly into barb on select valve
4. Failure of unit to turn off	a. Water valve parts dirty or defective b. Magnet doesn't fully return c. Excessive water pressure d. Mechanism hangs up	a. Clean* or replace with valve parts kit b. Make sure magnet moves freely. Replace spring if short or weak c. Install regulator if pressure (with water flowing) exceeds 60 PSI d. Be sure bracket is free to move and not broken
5. Excess foaming in discharge	a. Air leak in chemical pick-up tube	a. Put clamp on tube or replace tube if brittle

* In hard water areas, scale may form inside the discharge end of the eductor, as well as in other areas of the unit that are exposed to water. This scale may be removed by soaking the eductor in a descaling solution (deliming solution). To remove an eductor located in the cabinet, firmly grasp water valve and unthread eductor. Replace in same manner. Alternatively, a scaled eductor can be cleaned (or kept from scaling) by drawing the descaling solution through the unit. Operate the unit with the suction tube in the descaling solution. Operate the unit until solution is drawn consistently, then flush the unit by drawing clear water through it for a minute. Replace concentrate container and put suction tube into concentrate.



TaskMizer

Select + 1
with E-Gap Eductors
and Remote Fill
Model 48761

- Package Should Contain:**
1. Proportioner unit with discharge tubes.
 2. Chemical inlet tubing, 1/4" x 21'.
 3. Mounting Bracket.
 4. Dispensing Gun.
 5. Accessory kit containing:
(1) "Y" hose barb, (5) in-line check valves, (4) weights, (4) foot strainers, (2) metering tip kits, (3) mounting screws and (3) anchors.
 6. Instruction sheet.

THANK YOU FOR YOUR INTEREST IN OUR PRODUCTS

Hydro Systems manufactures quality chemical proportioning equipment. Please use this equipment carefully and observe all warnings and cautions.

*****NOTE *****

WEAR	protective clothing and eyewear when dispensing chemicals or other materials.
ALWAYS	observe safety and handling instructions of the chemical manufacturers.
ALWAYS	direct discharge away from you or other persons or into approved containers.
ALWAYS	dispense cleaners and chemicals in accordance with manufacturer's instructions. Exercise CAUTION when maintaining your equipment.
KEEP	equipment clean to maintain proper operation.
WEAR	protective clothing and eyewear when working in the vicinity of all chemicals, filling or emptying equipment or changing metering tips.
ALWAYS	re-assemble equipment according to instruction procedures. Be sure all components are firmly screwed or latched into position.
ATTACH	only to tap water outlets (85 PSI maximum).
NOTE	If the unit is used to fill a sink or the discharge hose can be placed into a sink, the unit must be mounted so that the bottom of the cabinet is above the overflow rim of the sink.

Installation and Operation:

1. Find suitable place close to water source for unit. Mounting bracket should be installed approx. 5' from floor. Level bracket & mark holes. Drill 9/32" holes & install mounting anchors and screws in bracket.
2. Hang cabinet on bracket. Mark hole for lower cabinet screw. Remove unit & drill 9/32" hole. Install anchor and screw to lower unit hole. When mounting unit do not mount any higher than 5 feet from the floor. Also, never mount your concentrate container higher than the unit.
3. Select 4 metering tips for the selector valve attached to the low flow (gray) eductor, and 1 tip for the hose barb attached to the high flow (yellow) eductor. Push each tip firmly into a separate hose barb. A clear tip with no hole can be used to block any valve port not being used, which may be used for dispensing water.
4. Cut tubing provided into separate supply tubes for each product to be dispensed. Supply tubes should reach from hose barbs to bottom of concentrate containers. Slide ceramic weights over one end of each tube and slide foot strainer into the same ends of the tubes. Remember to include check valves in the proper places in the supply tubing, colored end facing eductor body as shown (see diagram Page 3). Additional tubing is provided for drain hole in bottle fill drip tray. **NOTE: When routing pickup line(s) through unit, direct pickup line through clip(s) in cabinet back to ensure proper operation. (see diagram 1)**
5. Place strainer ends of supply tubes into concentrate containers.
REMEMBER TO CHECK STRAINERS PERIODICALLY FOR CLOGGING: CLEAN IF NECESSARY.
6. Replace unit cover. Be sure cover is labeled to allow identification of products to be dispensed.
7. Connect water supply hose to water inlet swivel. (Minimum 25 PSI pressure, with water running, is required for proper operation.) Turn on water supply.
8. Purge air from system by repeated rapid depressions of activating devices. The bottle fill activates by inserting a spray bottle over the discharge tube and lifting lever until flow starts. To stop flow, lower bottle off discharge tube. The bucket fill activates by holding and depressing lever of gun. To stop flow, release lever. The lever can be locked on by flipping clip to hold lever. **CAUTION: Lever must be manually unlocked to stop flow. Overflow will result if left locked in open position.**

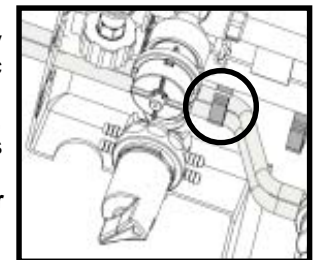

DIAGRAM 1



A DOVER RESOURCES COMPANY

3798 Round Bottom Road, Cincinnati, OH 45244 U.S.A. • Phone: (513) 271-8800 • Fax: (513) 271-0160 • www.hydrosystemsco.com

10088670
8/00

Metering Tip Selection:

The final concentration of the dispensed solution is related to both the size of the metering tip opening and the viscosity of the liquid being siphoned. For water-thin products, the chart at right can be used as a guideline. If product is noticeably thicker than water, consult the Measurement of Concentration Procedure below to achieve your desired water-to-product ratio. Because dilution can vary with water temperature and pressure, actual dilution achieved can only be ascertained by using the Measurement of Concentration Procedure. The clear, undrilled tip is provided to permit drilling to size not listed should you need a dilution ratio that falls between standard tip sizes.

NOTE: Refer to parts diagram if unfamiliar with names of system components.

Measurement of Concentration:

You can determine the dispensed water-to-product ratio for any metering tip size and product viscosity. All that is required is to operate the primed dispenser for a minute or so and note two things: the amount of dispensed solution, and the amount of concentrate used in preparation of the solution dispensed. The water-to-product ratio is then calculated as follows:

APPROXIMATE DILUTIONS AT 40 PSI FOR WATER-THIN PRODUCTS (1.0 CP)				
Tip Color	Orifice Size	Std. Drill Number	Ratio (per Eductor Flow)	
			1 GPM	3.5GPM
No Tip	.187	(3/16)	3:1	3.5:1
Grey	.128	(30)	3:1	4:1
Black	.098	(40)	3:1	4:1
Beige	.070	(50)	4:1	8:1
White	.043	(57)	7:1	20:1
Blue	.040	(60)	8:1	24:1
Tan	.035	(65)	10:1	30:1
Green	.028	(70)	16:1	45:1
Orange	.025	(72)	20:1	56:1
Brown	.023	(74)	24:1	64:1
Yellow	.020	(76)	32:1	90:1
Aqua	.018	(77)	38:1	128:1
Purple	.014	(79)	64:1	180:1
Pink	.010	(87)	128:1	350:1

$$\text{Dilution Ratio (X:1)} \text{ where } X = \frac{\text{Amount of Mixed Solution} - \text{Amount of Concentrate Drawn}}{\text{Amount of Concentrate Drawn}}$$

Dilution Ratio, then, equals X parts water to one part concentrate (X:1). If the test does not yield the desired ratio, choose a different tip and repeat the test. Alternative methods to this test are 1) pH (using litmus paper), and 2) titration. Contact your concentrate supplier for further information on these alternative methods and the materials required to perform them.

TaskMizer Parts Diagram List:

Key	Part No.	Description
1	10079003	Magnet Cover w/ chain slot
2	10079000	Magnet
3	10079010	Spring, Magnet return
4	90074612	Ball chain w/ sleeves
5	10075980	Valve parts kit d. diaphragm e. armature f. spring g. valve bonnet
6	10075925	Pipe plug, 3/8 npt x 2.54
7a	290	1GPM E-Gap Eductor Assm.
b	291	3.5 GPM E-Gap Eductor Assm.
8	10088852	Discharge tube assm.
9	10080957	Selector Valve Kit (short) a.support clip b.suction stub c. o-ring d. select valve assembly
10	690014	Metering tip kit
11	10075156	Street elbow, 3/8 npt
12	10082830	Swivel collar
13	10082801	Swivel stem
14	238100	Strainer washer
15	90076912	Yoke cable
16	507300	Clip Adjustment
17	90076913	Cable bead chain (2)
18	3401-R	Hose barb, 1/4"
19	10088619	Gun/cable assembly
20	500821	Tubing, 1/4" x 21'
21	10089401	Check valve
22	10068721	Y hosebarb, 1/4"
23	509900	Weight
24	609600	Foot strainer

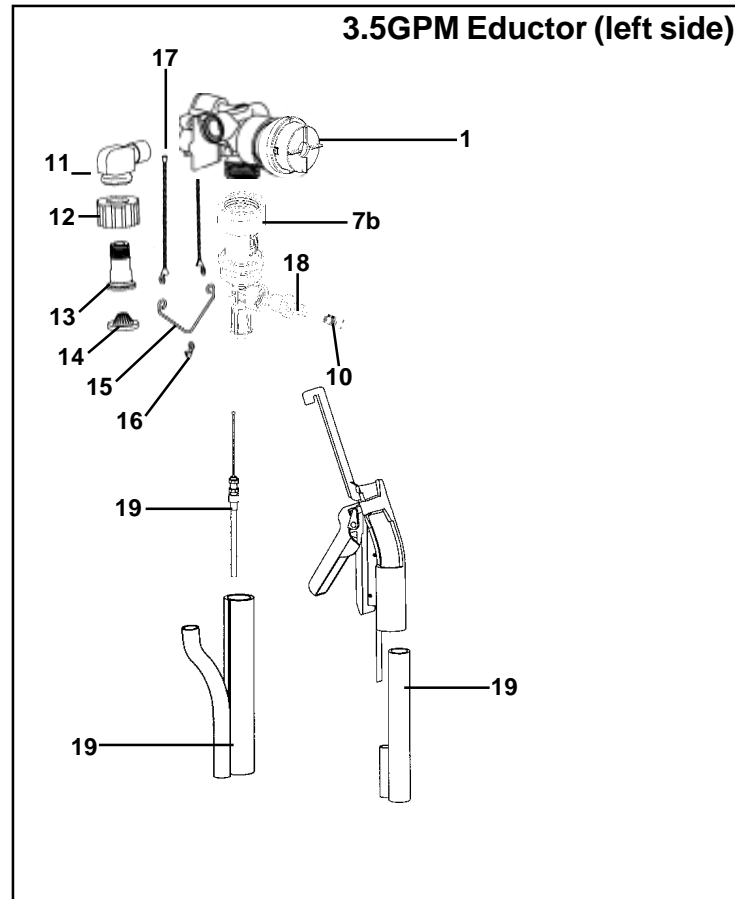

TaskMizer Parts Diagram Cont.

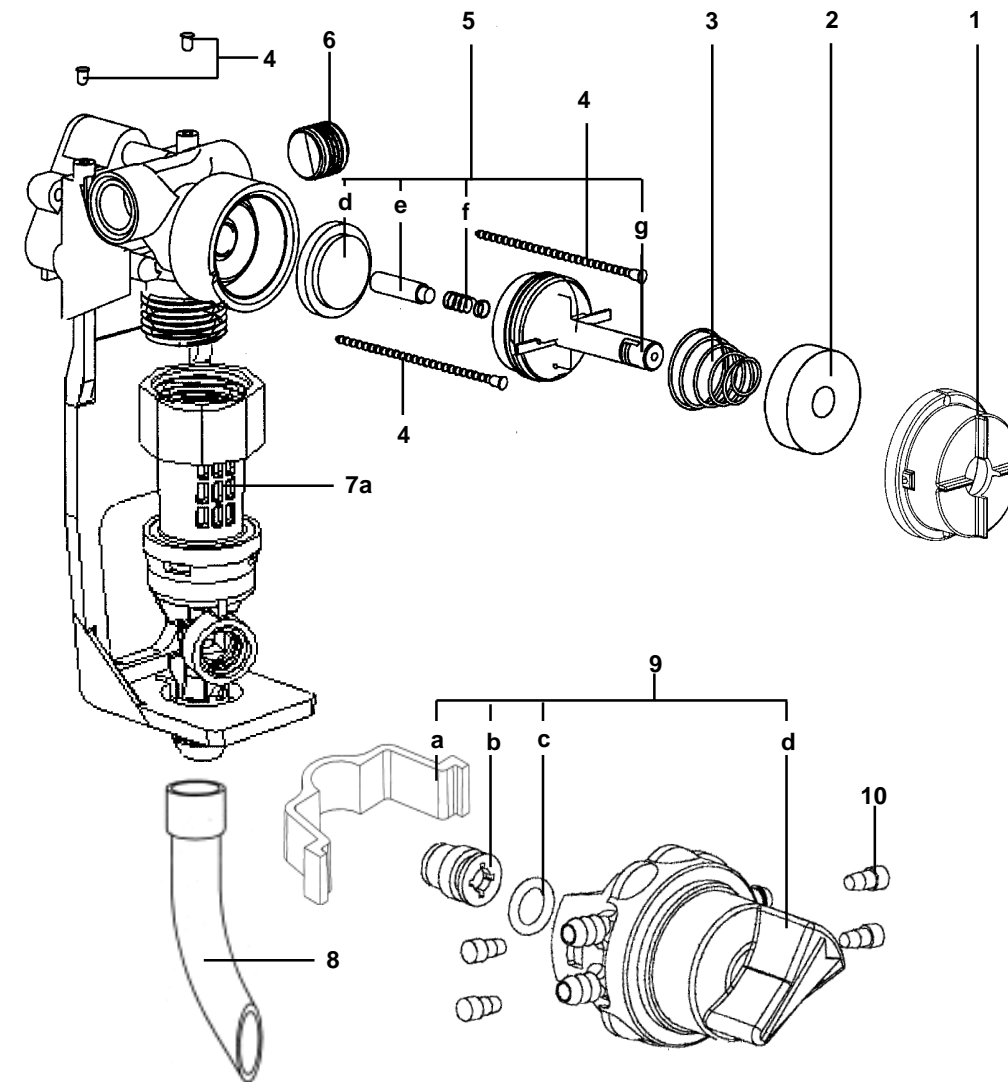

Dual Dilution Pickup Line Assembly: Single Product

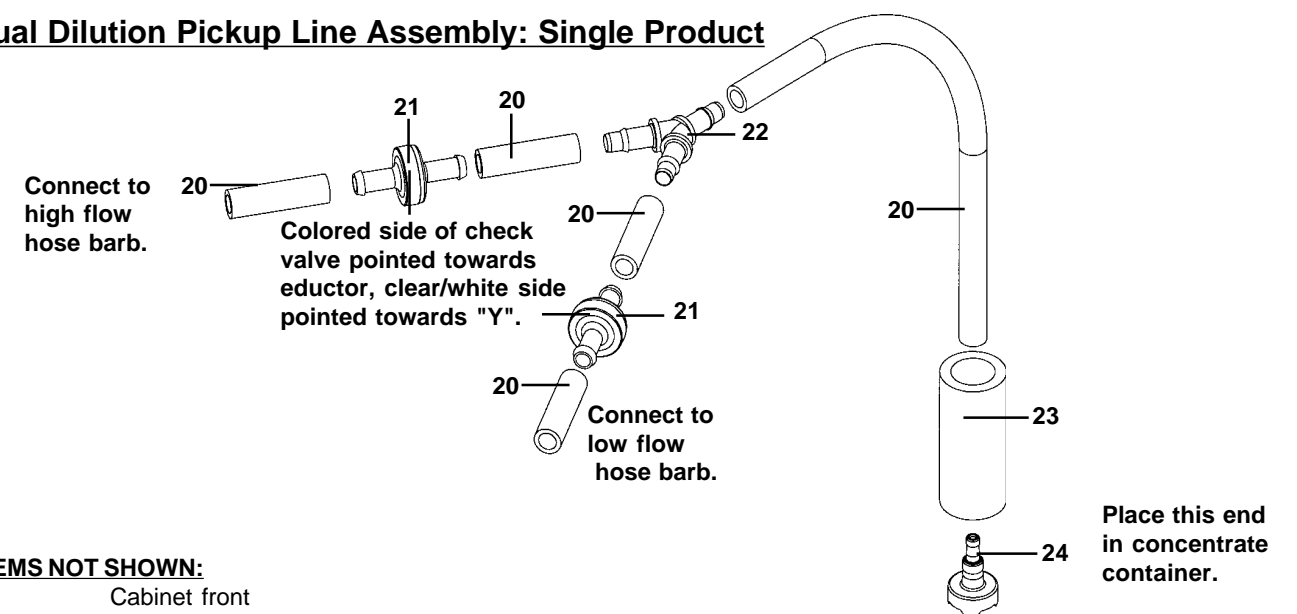

ITEMS NOT SHOWN:

- Cabinet front
- Cabinet back
- 10088609 Mounting bracket
- 10088608 Drip tray
- 641751 Security screws (for cabinet sides)