



# UltraDose™

## Automatic Dispensing System

The *UltraDose*™ is a battery operated peristaltic pumping dispenser which runs automatically at preset times as programmed on an electronic timer/control mechanism. Model 1120 is powered by two 6-volt lantern batteries, while Model 1160 gets its power from eight D-cell batteries. Both models mount on top of a 5-gallon pail and have a Norprene pump tube.

### THANK YOU FOR YOUR INTEREST IN OUR PRODUCTS

Please use this equipment carefully and observe all warnings and cautions.

\*\*\*\*\*NOTE\*\*\*\*\*

- ALWAYS** observe safety and handling instructions of the chemical manufacturers.
- ALWAYS** direct discharge away from you or other persons or into approved containers.
- ALWAYS** dispense cleaners and chemicals in accordance with manufacturer's instructions. Exercise CAUTION when maintaining your equipment.
- KEEP** equipment clean for proper operation.
- WEAR** protective clothing and eyewear when working in the vicinity of all chemicals, filling or emptying equipment or changing tubes.
- ALWAYS** re-assemble equipment according to instruction procedures. Be sure all components are firmly screwed or latched into position. Assure that hoses and electrical wires are properly placed and not kinked or pinched.

### INDEX OF CONTENTS

#### OPERATION AND MAINTENANCE OF THE *UltraDose*™ DISPENSER

Batteries  
 installation ..... Page 2

Dosage  
 determining the proper dosage for your application ..... Page 2

Timer  
 information ..... Page 2  
 programming ..... Page 2, 3  
 troubleshooting/tips ..... Page 3

System  
 diagram ..... Page 5  
 installation ..... Pages 3, 4  
 parts list ..... Page 5  
 specifications ..... Page 7  
 troubleshooting ..... Page 7  
 wiring diagram ..... Page 6

Tube  
 changing ..... Page 4  
 selection guide ..... Page 7

**This package should contain:**

1. One *UltraDose* dispenser -- pump, electronic timer/control, battery holder and motor in plastic pail bonnet.
2. Inlet tube with weight and strainer.
3. Discharge tube (10 ft.).
4. Injection fitting.
5. Cable ties (25).
6. Tubing barbs (2).
7. Instruction sheet.

### Determining the proper dosage/setting for your application:

The dispenser has a 3.5-ounce per minute average flow rate. New batteries will produce a dispense rate of a little more than 3.5 ounces per minute. After the first few running hours, the dispense rate will be approximately 3.5 ounces per minute and remain close to that for the balance of the practical battery life (40 total running hours). The minimum dispensing time is one minute. (If a minimum dispense of less than 3.5 ounces is desired, inquire about smaller capacity tubes.)

1. See the instructions for the treatment product to determine how much should be dispensed in each dose. Using the fact that each minute the pump runs 3.5 ounces of treatment dosing, determine how long each dosing period should be. For example, if the treatment instructions call for 6 ounces to be dosed each time, program the dispenser to run for two minutes (an approximate 7-ounce dose). Always round to the next highest full minute in this determination.
2. See the instructions for the treatment product to determine when the dosing is to occur. Program the timer to dispense at the appropriate times. Set the timer so that the pump runs for the number of minutes as determined in step 1 above.

### **CAUTION:**

**It is good practice to set the AUTO switch to OFF (O) prior to performing any service to the system.**

### BATTERY INSTALLATION:

1. Turn the unit right side up (as it would sit on a pail), remove the three screws and lift the top off.
2. a. *If installing Model 1120:*  
Batteries should be placed, spring terminals first, in the area of the system base with the metal contact grids.
- b. *If installing Model 1160:*  
Place eight D-cell batteries into the holder supplied, as shown by the diagrams in the holder. Place the holder in the open area behind the pump. Slide the foam block supplied between the battery holder and the molded support posts to keep battery holder from sliding within the compartment. Connect the plug on the battery holder to the plug on the wire harness.
3. Using battery life as 40 running hours, determine when to replace the batteries. Write a safe replacement date on the label supplied and place it visibly on the dispenser. (Using pencil allows changing the replacement date each time.)
4. **WHEN REPLACING BATTERIES**, turn the AUTO (left side) switch on the timer to the OFF (“O”) position before changing batteries. **AFTER** the new batteries are installed, slide the AUTO switch to ON (“I”) position to be sure power is supplied to the pump motor, then back to automatic (center) position so that system runs according to the programmed settings.

### TIMER INFORMATION/PROGRAMMING:

The timer clock operates in the military/24-hour mode. The time must be set before any of the other functions (priming, setting, programming) will operate. The timer can be programmed with up to eight dispensing cycles. Each cycle can be set to dispense as long as needed. The shortest time interval is one minute. A timed period can occur on just one day of the week, or it can be set to occur on one of several groups of days. The available groups of days (with day 1 being Monday) are:

- 1, 2, 3, 4, 5 (Monday through Friday)
- 1, 2, 3, 4, 5, 6 (every day but Sunday)
- 6, 7 (Saturday and Sunday)
- 1, 2, 3, 4, 5, 6, 7 (every day)

The program repeats each week. Each dispense cycle is started by an “ON” event and stopped by an “OFF” event. The ON events are odd numbered and have a “light bulb” in the display. The OFF events are even numbered.

The power to run the timer comes from the main power source (batteries). There is an internal backup battery that will run the timer if the main power is interrupted (changing batteries, dead batteries). This internal battery should last at least four years and is not replaceable. The timer will function without this battery, but the time and program will be lost if there is an interruption of the main power.

#### Controls:

There are two switches above the timer display. Both of these switches have three positions. After the timer is programmed, both switches should be in their center position for the timer to control the pump. The left switch (AUTO) controls the mode of operation. Far left (“I”) turns the pump on for priming and to check that the main power is connected properly. The center position allows the program to start and stop the pump. This is the normal position for this switch. Far right (“O”) turns the pump off. This will not allow the program to turn the pump on. If the pump is not going to be put in service right after it is programmed, this switch should be in the “O” position until it is used. The right switch (RUN) is used to set the time and the program. The far left (“P”) position is used to set the current time. The center position allows the timer to run and control the pump. This is the normal position for this switch. The far right (“R”) position is used to set or review the program.

The timer display has a lot of information about the timer’s function.

- At the top of the display are seven triangles. In normal operation, one triangle is visible under the current day of the week (Monday is day 1). When the program is being set or reviewed, a triangle will be visible under each day the event is to happen.
- The center of the display is the time. During normal operation, this should have the current time, and the colon “:” between the hour and minute should be flashing.
- To the right of the time, there is a small light bulb. This will be visible any time the pump should be running. It also comes on when the “pump start” time is being programmed.
- Below the “light bulb” is a symbol “~~X~~”. This symbol is displayed when the skip function is activated.

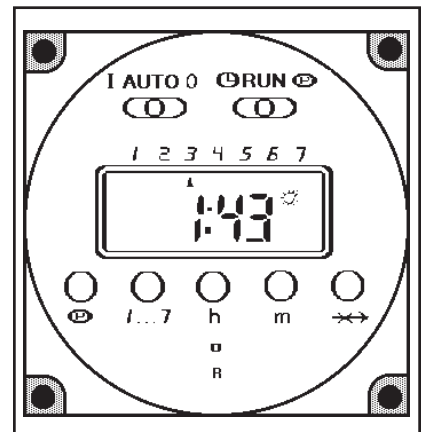

Below the timer display, there is a row of buttons. Except for the far right button, these buttons can only be used when the RUN switch is in the right or left position. They will not do anything when the RUN switch is in the middle position. The button under the time display to the far left ("P") is used to index to the next event while setting or reviewing the program. A button labeled "1...7" is used to select the day of the week when setting the time or program. The "h" button is used to set the hour and "m" is used to set the minute for clock or event times. The "X" button activates the "skip" function, and allows the timer to skip the next day's program. The same symbol is displayed when this feature is activated. Pressing the button again will turn this function off. During the day that is being skipped, the small triangle indicating that day flashes. Once the skipped day has started (midnight), the "skip" function cannot be cancelled. The pump can be run manually.

**Please note: Below this row of buttons is the RESET button, marked "R", which resets the timer when pressed, erasing all programming and time information.** The display will flash "00:00", and a triangle will be displayed under the "1". You will need a small point (the end of a pen or pencil) to push this button.

**Programming:** (Put the AUTO switch to "O" first.)

1. Set the time of day: MUST BE DONE FIRST.
  - Slide the RUN switch to the left.
  - Press "1..7" to move the triangle under the current day of the week (1 is Monday).
  - Press "h" and "m" to set the time of day.
2. Set the program:
  - Slide the RUN switch to the right.
  - Press "h" and "m" to set the start time for the first dispense.
  - Press the "1...7" to set the day(s) for this dispense.
  - Press the "P" to program the OFF event.
  - Press "h" and "m" to set the stop time for the first dispense.
  - Press the "1...7" to set the days for this stop event (be sure the day(s) selected match those indicated while programming the ON/dispensing event).

To program more than one dispense cycle, press "P" to go to the next ON event. Repeat steps in 2 for each cycle.

3. Start the dispenser:
  - Move the RUN switch to the middle position.
  - Move the AUTO switch to the middle position.
4. Priming the pump:
  - Move the AUTO switch to "I" to prime the pump. Return this switch to the middle position to allow the program to run.
5. Replace the cover.

**Timer Troubleshooting and Tips:**

1. The display shows "E E E" when the RUN switch is moved to the right: The time must be set first.
2. Nothing happens when the AUTO switch is moved to "I":
  - Does the "light bulb" appear in the display?
  - NO: The time must be set first.
  - YES: One of the following may be the problem:
    - Batteries not installed correctly.
    - Batteries dead.
    - Wiring is not connected correctly. See diagram.
    - Pump is bound - remove pump and try again.
    - Timer or motor is bad.
3. The pump starts when both AUTO and RUN switches are moved to their center position:
  - There is a dispense cycle programmed to run at this time.
  - One of the OFF events does not have the days set.
4. An event is programmed but not needed:
  - To remove an event: Slide the RUN (right) switch to the right ("P"). Use the "P" button (below display, far left) to move to the event you want to remove. Press and hold the far right button "X". While pressing this button, also press and hold the "P" button. The event will clear in three to four seconds. Be sure to remove both the ON and OFF events.

**SYSTEM INSTALLATION:**

Determine where to locate the dispenser and pail of chemical. Choose a place away from traffic. Bumping the dispenser may knock it over if the pail is almost empty.

1. If you haven't, program the dispenser (see above).
2. Install the supply tube provided (2 feet of clear tube) onto the inlet tube stem of the pump (lower tube) with the black, barbed, "L" fitting. Secure with cable ties around the tubes over the barbs. Insert clear tube through hole in cabinet below the pump tube. Slide the white, ceramic weight over the free end of the supply tube, then insert the clear plastic strainer assembly in the end of the tube. (See diagram at right.) This assembly will be in the container of liquid.
3. The remaining barbed fitting has different ends: Insert the larger end into the discharge side of the pump. Secure the fitting to the tube with a cable tie.

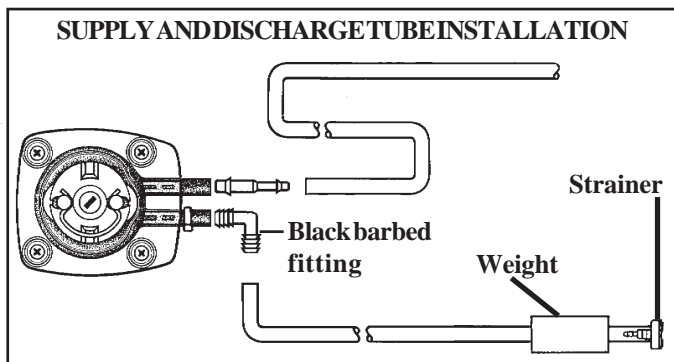

4. Connect the discharge tube (10-ft. "white" polyethylene) to the dispenser. Slide the tube over the smaller end of the fitting in the discharge side of the pump tube.
5. Draw the discharge tube to the pipe or area to be dosed. If the injection fitting will be used, go to step 6. If not, go to step 7.
6. Drill and tap the pipe for the 1/8" NPT injection fitting. The fitting can be drilled through to allow the tubing to pass into the pipe if necessary. Screw the injection fitting into the pipe. Tighten the fitting to provide a positive seal.
7. Determine where the discharge tube will be secured to walls, floor, tables, etc. Cut the tubing to the appropriate length for such installation. Connect the tubing to the injection fitting. Be sure the tubing will be out of the way of traffic and will not impede motion required in the area. Creating a low place in the run of tubing near the fitting will minimize drainage from the tubing.
8. Open the pail of treatment product. Drop the strainer end of the supply tube into the pail. Place the dispenser on the container.
9. Prime the pump. Remove the cover and open the timer box. Move the AUTO switch to "I". Run the pump until product has filled all tubing and has just begun to be discharged. (NOTE: A tube that has sat over night in the pump and/or is cold will also take longer. This phenomenon does not occur when the tube has liquid in it.) Return the programmer to automatic mode (both switches in center position) to operate the dispenser according to the programmed schedule. Check the set-up seven to 10 days after installation to insure proper operation and dosage.
10. Close the timer box. Replace the cover.

### Changing the pump tubing:

You may want to work over old newspapers or other discardable material to protect floors or other areas from the possibility of spilled treatment. Be sure the AUTO switch (left side of programmer) is OFF (O -- to the right). Refer to the diagrams below for illustration of selected steps.

1. Cut cable ties which secure the supply and discharge tubing barbs to the tube stems on the pump. Remove the barbs from the pump tubing ends (tube stems). Hold the tubes so that the treatment does not drip from the tubes. Lay aside the supply and discharge tubing.
2. Remove long screws from pump (upper left and lower right). Remove pump from cabinet (see left diagram below).
3. Remove two remaining (short) screws. Lift the clear pump cover from the pump and lay it aside.
4. Turn the rotor assembly so that the rollers are in vertical alignment (one above the other). Pull gently but firmly until the rotor assembly is dislodged from the pump housing (see center diagram below).
5. Remove old tubing and discard it. If drain treatment leaks on pump housing, it can be washed in soapy water. If the rotor assembly has been wetted, wipe it with a dry cloth. It is not necessary to wipe the grease from the pump housing if the grease is clean. While the pump is disassembled, inspect all parts for foreign matter and clean the parts as required. Be sure the rollers turn freely. If the rotor needs service, replace the entire rotor.
6. Put a dab of Tube Lube on each end of the rotor assembly shaft (bearings).
7. Position the pump housing so that the tube exit channels are toward you.
8. Bend the new tube in half over one of the rollers in the rotor assembly. Place this roller with the tube into the top of the pump housing (farthest away from you). Press the other roller into the bottom of the housing (closest to you).
9. Push each end of the tube into the exit channels. A small amount of Tube Lube in each channel will help. **Be sure the tube is not at all twisted when you do this.** A twist in the tube may prevent pumping.
10. Place a dab of Tube Lube on the lower roller as shown. Further lubing during operation is not needed.
11. Replace the clear cover and install the two short screws into the brass inserts in the pump body.
12. Put a cable tie on the inlet tube stem (left side as viewed from front) just below the pump housing. This will prevent the tubing from "walking" through the pump as the pump operates.
13. Reinstall the pump on the motor shaft extending from the system cabinet and replace the two long screws.
14. Re-attach the supply and discharge tubing along with the barbed fittings. Secure the barbs with cable ties around the pump tube stems.
15. Prime the unit using the AUTO (left side) switch: Slide the switch to the left ("I") position. Make sure the pump is turning freely (see right diagram below).
16. Return the pump control to automatic by setting AUTO switch to center position.

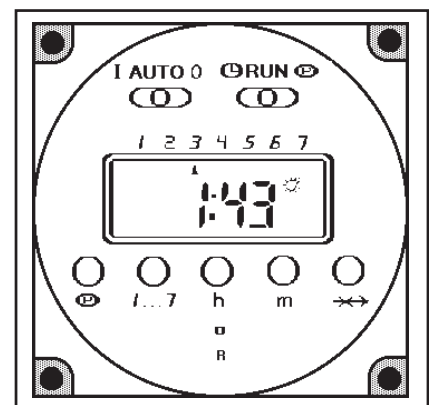
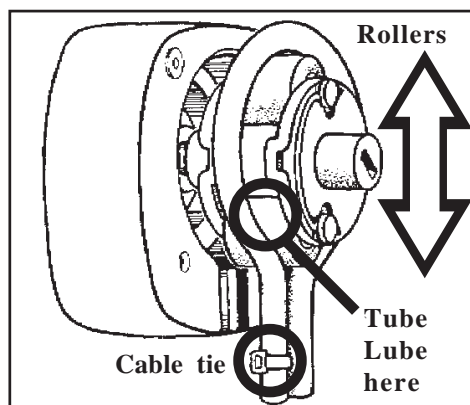
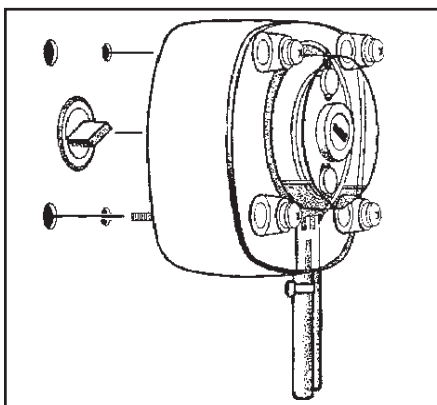

**System Diagram and Parts List**

<b>Key</b>	<b>Part #</b>	<b>Description</b>
1	10069148	Timer kit
2	10069108	Wire harness
3	10006103	Motor/gearbox
4	10016807	Complete pump kit, 4cc Norprene
	10016808	Complete pump kit, 4cc Viton
5	10006700	Pump body
6	10011702	Rotor assembly: a. wire spring, b. rotor core, c. roller with axle
7	10016007	Tubing: 4 cc with grease & cable ties
8	10006601	Pump cover
9	10005202	Screw, long
	10005201	Screw, short
10	10069351	Timer box with gasket
11	10069330	Timer cover (door)

**NOT SHOWN:**

10072600	"L" hose barb
10012801	Straight hose barb
10012301	Polyethylene tubing -- 1/4" x 20 ft.
10012302	Polyethylene tubing — 1/4" x 10 ft.
10027301	Pail tubing -- 1/4" I.D. x 32".
609600	Inlet tube strainer
509900	Ceramic weight
10016500	Cable ties (25)
10069109	Holder for D-cell batteries
10069327	Foam spacer
509100	Injection fitting

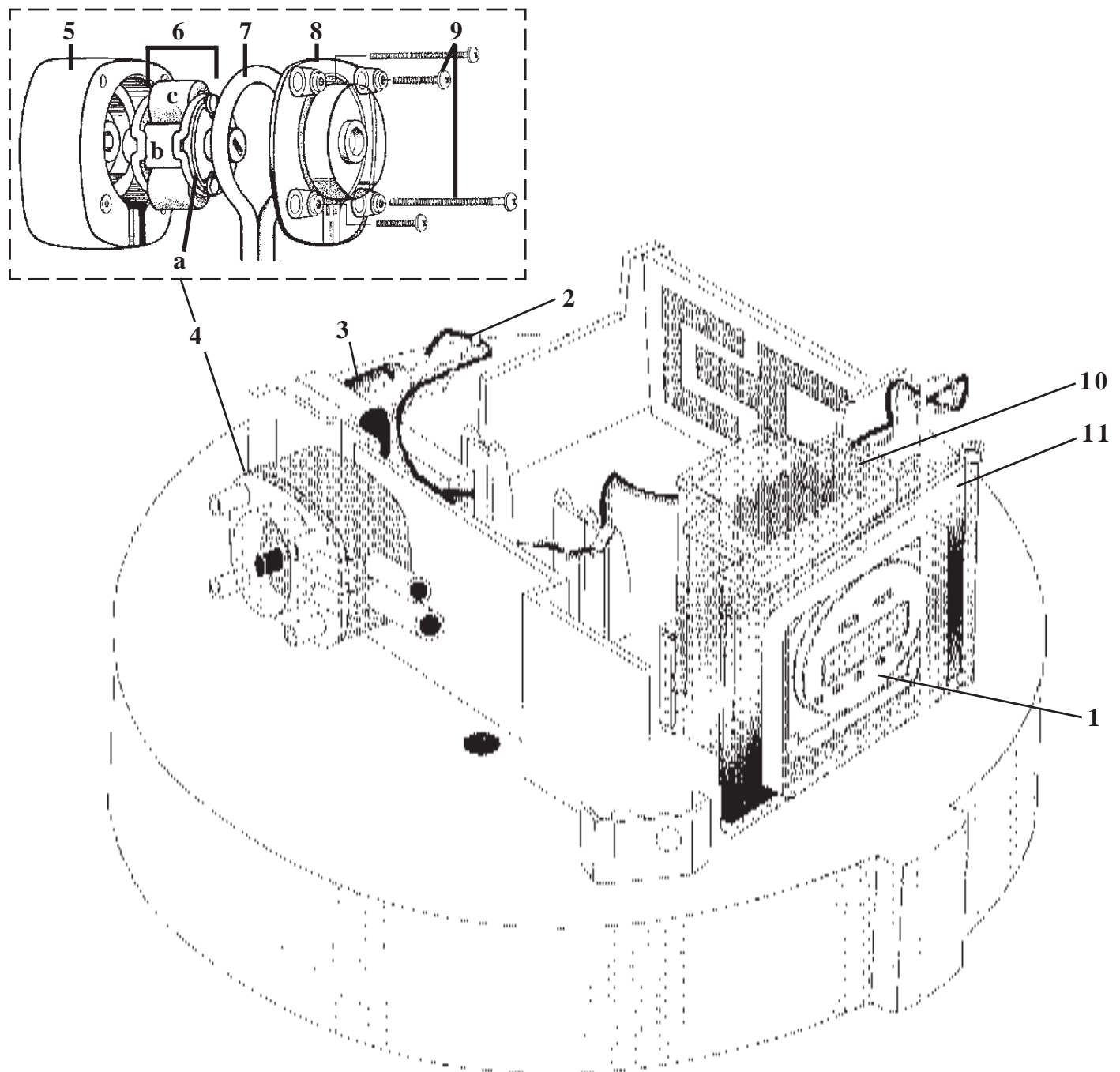

Wiring Diagram

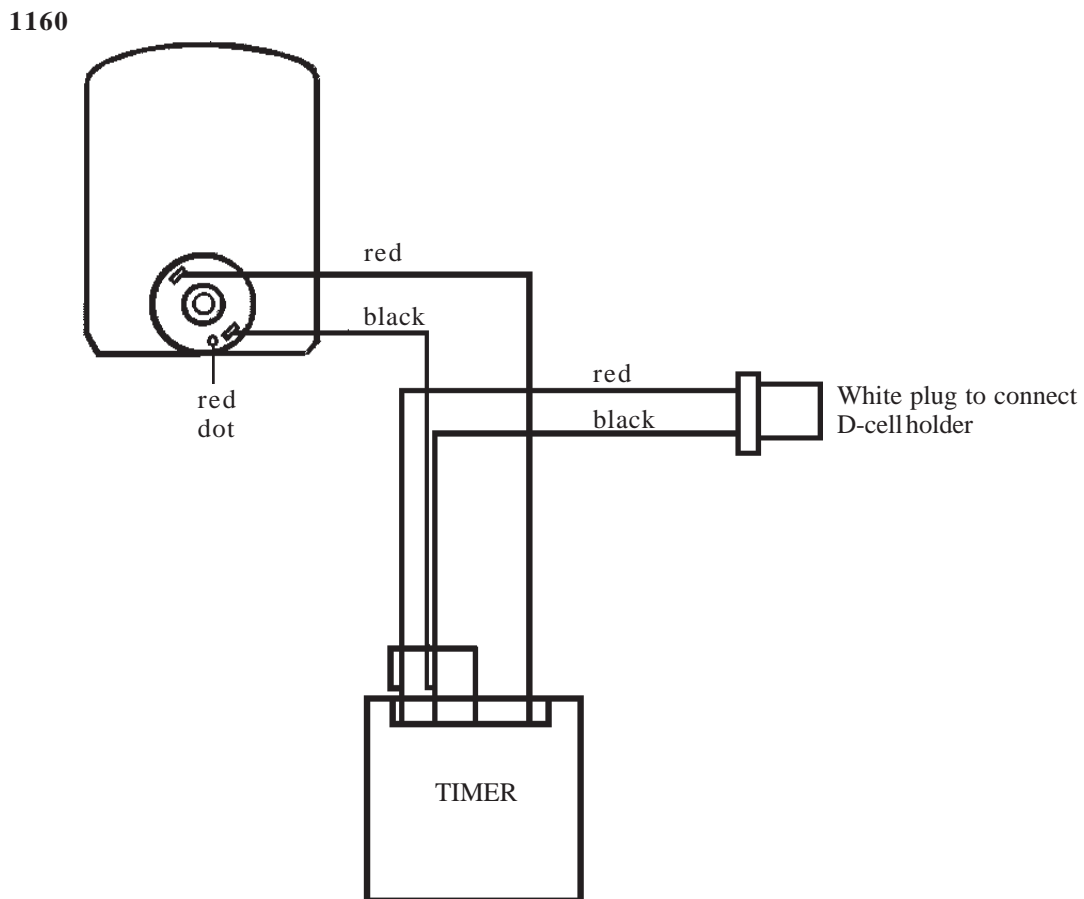
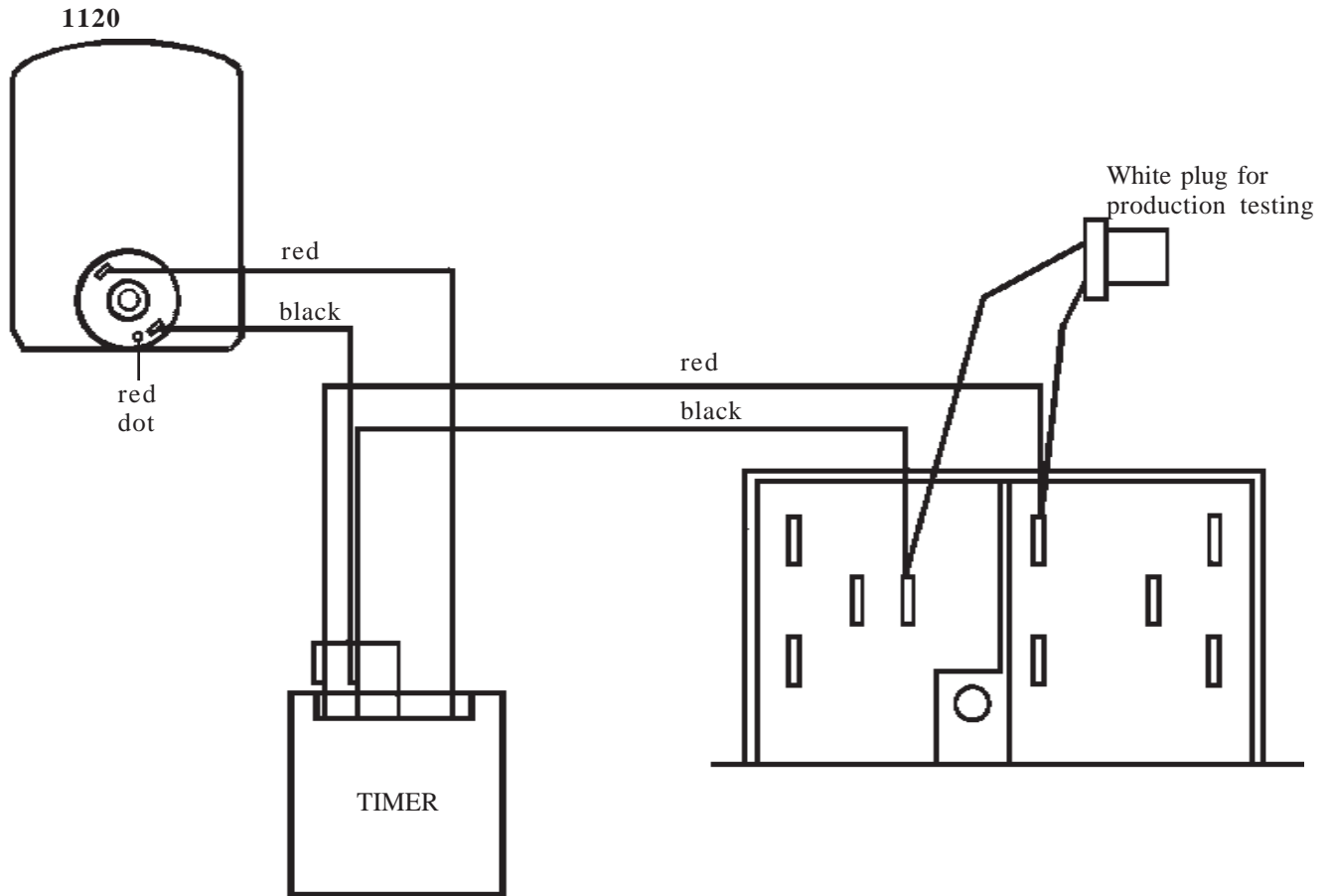

## **Troubleshooting:**

### **UNIT IS NOT PUMPING FLUID:**

Is the motor turning?

- YES >check level of drain treatment supply.  
>check for air leaks in the supply tubing connection to pump tube stems.  
>check for clogs in inlet and outlet tubes.  
>insure pump tube is not at all twisted.  
>check pump tube. As it wears out, the amount of fluid pumped decreases. Change tube.
- NO >insure programmer is functioning: Try to run pump manually (see page 3).  
>check program: Be sure both switches are in center position for programmed dispensing.  
>check to insure wires from the electronic control to the motor are secure.  
>insure that wire from batteries to electronic control is secure.  
>check battery condition. Try new batteries. **BE SURE TIMER IS OFF** before changing the batteries.  
>remove the pump to see if pump is binding the motor (follow instructions for priming the pump, see page 3).

### **UNIT IS PUMPING TOO MUCH FLUID:**

Is the tubing the proper ID for your application?

- NO >replace tubing with proper size.
- YES >check program to insure the required duration.  
>insure programmer is turning on and off at set times.  
>remember that fresh batteries will result in a slightly higher than average dispense.

### **PROGRAM TIMER IS "LOCKED UP" (does not respond to buttons pressed):**

Press reset. Reprogram timer.

---

---

### **Pail Pump Dispenser Specifications:**

#### **PUMP:**

Flow rate ..... 100 cc (approx 3.5 oz./min).  
Tube ..... Norprene 4cc  
Power: Model 1120 ..... Two 6-volt alkaline batteries\*,  
..... lantern size, spring terminals  
Model 1160 ..... Eight D-cell alkaline batteries\*  
Motor ..... DC, with gearbox  
Rotor assembly ..... Spring suspended rollers

\* Batteries are not included with the system as delivered

#### **SYSTEM CABINET:**

Material ..... Reinforced polypropylene  
Size ..... 7-3/4" tall x 14" diameter  
(does not include container/pail system sits on)

#### **PROGRAMMABLE TIMER/CONTROL:**

Program duration ..... 7 days  
Maximum # of events ..... 8 on/8 off per day  
Minimum time "on" or "off" ..... 1 min.  
Display ..... LCD

---

---

**NOTE:** Model 1120 can be converted to use D-cell batteries. Order the battery holder (P/N 10069109) and the foam spacer (P/N 10069327). Plug the battery holder into the white plug under the timer box.

---

---

**NOTE:** The batteries should be scheduled for periodic replacement. Using a total of 40 running (pumping) hours, create a schedule for servicing the unit and changing the batteries. Maintaining the power source in this fashion will help to provide the proper dosing by providing a more consistent pumping rate. **USE ONLY ALKALINE BATTERIES. CAUTION: ALWAYS TURN THE AUTO SWITCH TO THE "O" POSITION BEFORE CHANGING THE BATTERIES.**

---

---

### **Pump tubes available:**

<u>Part Number</u>	<u>Description</u>
10016007	4cc Norprene
10016008	4cc Viton

### **Tube Selection Guide**

TUBE	DRAIN TREATMENT TYPE
Viton	Solvents, Acids
Norprene	Bacterias, Enzymes, Detergents

Tube life will vary depending on the type of treatment product used. To prevent emergency service, schedule replacement at least once per year.



---

**Hydro Systems Company**

3798 Round Bottom Road, Cincinnati, OH 45244 USA

Phone: (513) 271-8800 • Fax: (513) 271-0160

**10090800**  
**5/07 Rev. A**