

**TROUBLESHOOTING CHART:**

Problem	Cause	Solution
1. No discharge	a. No water b. Magnetic valve not functioning c. Excessive water pressure  d. Eductor clogged	a. Open water supply b. Install valve parts kit c. Install regulator if flowing water pressure exceeds 60 PSI d. Clean* or replace
2. No concentrate draw	a. Clogged foot valve b. Metering tip or eductor has scale build-up c. Low water pressure  d. Discharge tube and/or flooding ring not in place  e. Concentrate container empty f. Inlet hose barb not screwed into eductor tightly g. Clogged water inlet strainer	a. Clean or replace b. Clean (descale)* or replace  c. Minimum 25 PSI (with water running) required to operate unit properly d. Push tube firmly onto eductor discharge hose barb, or replace tube if it doesn't have a flooding ring e. Replace with full container f. Tighten, but do not overtighten g. Disconnect inlet water line and clean strainer
3. Excess concentrate draw	a. Metering tip not in place	a. Press correct tip firmly into barb on eductor
4. Failure of unit to turn off	a. Water valve parts dirty or defective b. Magnet doesn't fully return  c. Push button stuck  d. Excessive water pressure	a. Clean* or replace with valve parts kit b. Make sure magnet moves freely. Replace spring if short or weak c. Realign cabinet or clean grommet that button passes through d. Install regulator if pressure (with water flowing) exceeds 60 PSI
5. Excess foaming in discharge	a. Air leak in pick-up tube b. Inner discharge tube not in place	a. Put clamp on tube or replace tube if brittle b. Install inner discharge tube
6. Water discharge from air vents of eductor	a. Restricted discharge hose  b. High water pressure	a. Be sure discharge hose is not immersed, kinked or elevated. Be sure there is no liquid in the discharge hose when beginning to operate dispenser b. Install pressure regulator if flowing water pressure exceeds 60 PSI

\* In hard water areas, scale may form inside the discharge end of the eductor, as well as in other areas of the unit that are exposed to water. This scale may be removed by soaking the eductor in a descaling solution (deliming solution). To remove an eductor located in the cabinet, firmly grasp valve and unthread eductor. Replace in same manner. Alternatively, a scaled eductor can be cleaned (or kept from scaling) by drawing the descaling solution through the unit. Operate the unit with the suction tube in the descaling solution. Operate the unit until solution is drawn consistently, then flush the unit by drawing clear water through it for a minute. Replace concentrate container and put suction tube into concentrate.

# Hydro<sup>®</sup> MaxiMizer™ ST Proportioning System

with HydroGap™ Air Gap Eductors: Model 1868AG-2

**Package Contains:**

- |                             |  |
|-----------------------------|--|
| 1. Proportioner unit.       | 5. Metering tip kits.                  |
| 2. Supply tubes.            | 6. Mounting anchor kit.                |
| 3. Foot valves and weights. | 7. Drip tray.                          |
| 4. Discharge tubes.         | 8. Hose hook for 3.5 GPM eductor only. |

**THANK YOU FOR YOUR INTEREST IN OUR PRODUCTS**

Hydro Systems manufactures quality chemical proportioners. Please use this equipment carefully and observe all warnings and cautions.

\*\*\*\*\* NOTE \*\*\*\*\*

<b>WEAR</b>	protective clothing and eyewear when dispensing chemicals or other materials.
<b>ALWAYS</b>	observe safety and handling instructions of the chemical manufacturers.
<b>ALWAYS</b>	direct discharge away from you or other persons or into approved containers.
<b>ALWAYS</b>	dispense cleaners and chemicals in accordance with manufacturer's instructions. Exercise <b>CAUTION</b> when maintaining your equipment.
<b>KEEP</b>	equipment clean to maintain proper operation.
<b>WEAR</b>	protective clothing and eyewear when working in the vicinity of all chemicals, filling or emptying equipment or changing metering tips.
<b>ALWAYS</b>	re-assemble equipment according to instruction procedures. Be sure all components are firmly screwed or latched into position.
<b>ATTACH</b>	only to tap water outlets (85 PSI maximum).

**Installation and Operation:**

- To install the tray wireform on the cabinet, lay the unit on its back. Insert the two wireform ends through only the front edge holes of the bottle rest. Install 2 palnuts approximately 4" up the wire ends. Place the drip tray securely into the wireform and push the wireform ends through the back edge holes of the bottle rest. Install 2 palnuts at the rear, with tray until flush with bottle rest.
- Unlock the front door panel and open it. The front panel can be removed by loosening the screws inside the bottom edge and then lifting the front off.
- To mount the unit to a wall, drill mounting holes and insert the plastic toggle anchors provided into the holes. Use the screws provided to secure the unit to the wall.
- Select a metering tip for each eductor (see next section) and insert the tip into the eductor hose barbs.
- Connect the long, flexible discharge tube to the bottom of the 3.5 GPM (yellow) eductor. A clamp for securing the 3.5 GPM tube is provided. Route the tube out the bottom of the unit, through the hole provided. The hook provided may be installed on the end of the tube. This allows the discharge tube to hang neatly when not in use. Gently twist the hook while pushing it over the end of the tube to ease installation. Make sure all discharge tubes are fully engaged onto the eductors.
- Connect water supply hose of at least 1/2" ID to water inlet swivel at right side of manifold. (Minimum 25 PSI pressure, with water running, is required for proper operation.) Route hose out the side of the cabinet, through the hole provided, and attach the hose to the water supply source. Turn water supply on.
- Install each suction tube as follows:
  - Slide a ceramic weight over one end of the piece of tubing.
  - Push the hose barb end of a foot valve into one end of the open tube.
  - Slide the weight down to the foot valve.
  - Place foot valve end of suction tube into the concentrate container and put container into proportioner cabinet.
  - Push the other (open) end of the suction tube assembly over the hose barb/metering tip on the eductor.
  - REMEMBER TO CHECK FOOT VALVE STRAINER FOR CLOGGING PERIODICALLY. CLEAN IF NECESSARY.
- Close front door panel and lock. Be sure the drip tray is in its place in the wire form provided.
- Write product names on the labels supplied and apply the labels under the buttons to correspond to the product that will be dispensed by depressing each button, and the types of containers the solutions will be dispensed into.
- Purge air from the system by depressing the buttons briefly. There may be some water discharge from the eductor vents until the air is purged.
- Push button to start flow of desired water/concentrate solution, and hold until solution starts to be discharged. (Be sure to have a bottle or other receptacle under the discharge tube.) Prime each of the supply tubes in this way. Then push the button whenever dispensing is desired, and release button to stop flow of solution. Buttons may be converted to twist-to-latch locking buttons by installing the latch spring provided (see parts diagram for placement). This allows continuous dispensing without holding button.
- It is essential that the discharge hose not be obstructed. If discharge is restricted, water will flow out the eductor vents. Do not start to operate the dispenser with liquid in the discharge tube.**



**Metering Tip Selection:**

The final concentration of the dispensed liquid is related to both the size of the metering tip opening and the viscosity of the liquid being siphoned. If product viscosity is noticeably greater than that of water, consult the procedure for Measurement of Concentration on the next page to achieve your desired water-to-product ratio. For water-thin products, use the chart on the next page as a **guideline**. Because such factors as inlet water pressure and temperature can affect dilution ratios, the figures listed on the chart are only approximate. Test the actual dilution you are achieving using the Measurement of Concentration procedure for best results. Use the undrilled, clear tip for drilling a size not listed.

**Measurement of Concentration:**

To determine the dispensed water-to-product ratio for any metering tip size and product viscosity, operate the primed dispenser for a minute or so and note the amount of dispensed solution, and the amount of concentrate used in preparation of the solution. These values can be placed in the equation below to determine the achieved dilution ratio. Dilution Ratio equals X parts water to one part concentrate (X:1). If the test does not yield the desired ratio, choose a different tip and repeat the test. Alternative methods to this test are 1) pH (using litmus paper), and 2) titration. Contact your concentrate supplier for further information on these alternative methods and the materials required to perform them.

$\text{Dilution Ratio (X:1) where X = } \frac{\text{Amount of Mixed Solution} - \text{Amount of Concentrate Drawn}}{\text{Amount of Concentrate Drawn}}$
--

APPROXIMATE DILUTIONS AT 40 PSI FOR WATER-THIN PRODUCTS (1.0 CP)				
Tip Color	Orifice Size	Std. Drill Number	Ratio (per Eductor Flow)	
			1 GPM	3.5 GPM
No Tip	.187	(3/16)	3:1	3.5:1
Grey	.128	(30)	3:1	4:1
Black	.098	(40)	3:1	4:1
Beige	.070	(50)	4:1	8:1
Red	.052	(55)	5:1	14:1
White	.043	(57)	7:1	20:1
Blue	.040	(60)	8:1	24:1
Tan	.035	(65)	10:1	30:1
Green	.028	(70)	16:1	45:1
Orange	.025	(72)	20:1	56:1
Brown	.023	(74)	24:1	64:1
Yellow	.020	(76)	32:1	90:1
Aqua	.018	(77)	38:1	128:1
Purple	.014	(79)	64:1	180:1
Pink	.010	(87)	128:1	350:1

**MaxiMizer™ ST Parts Diagrams/List**

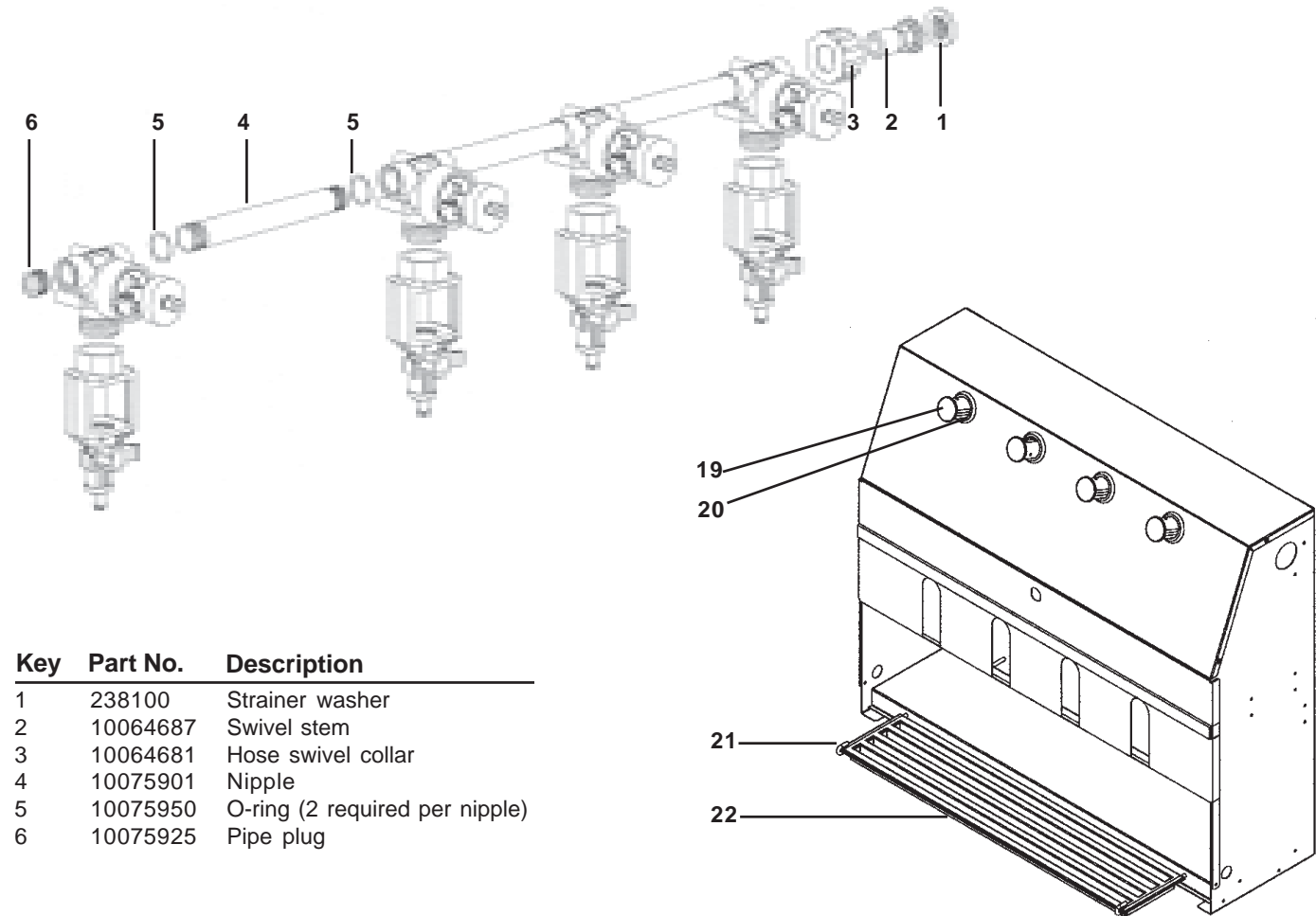

Key	Part No.	Description
1	238100	Strainer washer
2	10064687	Swivel stem
3	10064681	Hose swivel collar
4	10075901	Nipple
5	10075950	O-ring (2 required per nipple)
6	10075925	Pipe plug

**MaxiMizer™ ST Parts Diagrams/List**

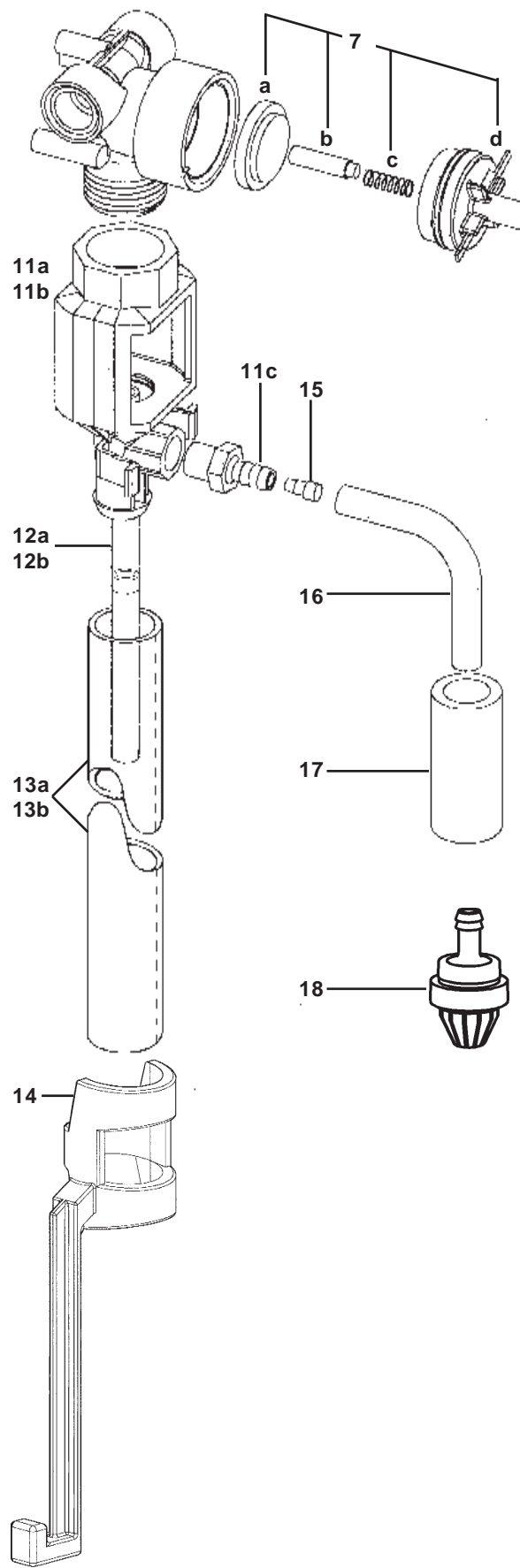

Key	Part No.	Description
7	10075980	Valve parts kit a. diaphragm b. armature c. spring d. valve bonnet
8	10079010	Spring
9	10079000	Magnet
10	10068835	Locking button kit (spring and screw)
11 a	170	1 GPM Eductor assembly
b	190	3.5 GPM Eductor assembly
c	3401-R	Eductor hose barb only
12 a	10070170	1 GPM inner discharge tube
b	10070470	3.5 GPM inner discharge tube
13 a	10077322	Outer discharge tube assembly, 3.5 GPM
b	90072840	Outer discharge tube assembly, 1 GPM
14*	10080720	Hose hook, dark grey (standard)
	10080721	Hose hook, sky blue
	10080722	Hose hook, red
	10080723	Hose hook, green
	10080724	Hose hook, light grey
	10080725	Hose hook, yellow
	* Hose hooks are for 3.5 GPM discharge tubes	
15	690014	Metering tip (kit)
16	10062550	Tubing, 1/4" x 2'
17	509900	Weight
18	10089410	Foot valve -- Viton (EPDM also available, order 10076302)
19	10077480	Button, dark grey (includes #20)
	10077481	Button, blue (includes #20)
	10077482	Button, red (includes #20)
	10077483	Button, green (includes #20)
	10077484	Button, yellow (includes #20)
	10077485	Button, light grey (includes #20)
	10082750*	Button, dark grey locking
	10082751*	Button, blue locking
	10082752*	Button, red locking
	10082753*	Button, green locking
	10082754*	Button, yellow locking
	10082755*	Button, light grey locking
	*Locking button parts kits include #20 grommet and #10 latch spring	
20	10068810	Grommet
21	10078591	Tray wireform with palnuts
22	10055001	Drip Tray

NOT SHOWN:  
 10029500 Lock  
 10018000 Key mounting clip  
 10029600 Keys (2) for lock  
 10075158 MSDS Envelope