

# THE DOSMATIC ADVANTAGE

## INSTALLATION AND OPERATING MANUAL

### For all A15 Models

A15-4ml  
A15-2.5%



This document is for information only and does not constitute a formal contract. Dosmatic reserves the right to modify the content at any time without prior notice.



# TABLE OF CONTENTS

INTENDED USE. ....	2
INSTALLATION. ....	2
DIAGRAM – TYPICAL INSTALLATION. ....	6
DIAGRAM – TANK-FEED INSTALLATION. ....	7
DIAGRAM – MOUNTING DIMENSIONS. ....	8
START-UP PROCEDURES. ....	9
CHEMICAL MIXING. ....	9
CHLORINATION. ....	10
USING YOUR INJECTOR. ....	10
How do I adjust the ratio setting. ....	10
How do I calculate my ratio setting and ppm. ....	10
Do I need to calibrate my injector. ....	12
Do I need to bleed my injector. ....	13
What chemicals can I use. ....	13
Can I inject two or more chemicals. ....	13
Can I use hot water to dissolve chemicals. ....	14
How do I store my injector. ....	14
MAINTENANCE. ....	14
Preventative maintenance. ....	14
Solution Filter. ....	15
O-ring Lubrication. ....	15
TROUBLE SHOOTING. ....	15
Injector not working. ....	15
Wear Parts Maintenance	
4ml Model. ....	16
2.5% Model. ....	18
REORDERING. ....	20
KITS AND PARTS LIST/DIAGRAMS. ....	21
4 ML. ....	21
4 ML DIAGRAM. ....	22
2.5%. ....	23
2.5% DIAGRAM. ....	24
RETURN AUTHORIZATION FORM. ....	25
DOSMATIC WARRANTY. ....	26
SPECIFICATIONS. ....	27
DECLARATION OF COMPLIANCE WITH CE. ....	27



## INTENDED USE

The Advantage A15 is a water-driven liquid injector designed to proportionally inject **completely dissolved** chemicals that are recommended and approved. These water-soluble solutions include: **Water-Soluble Fertilizers – Acids – Wetting Agents – Chlorine – Disinfectants – Iodine– Antibiotics**

It is the responsibility of the operator to determine proper solution injection ratios, mix the solutions, adjust the injector to obtain the desired solution concentrations in the outlet water and assure that proper injection ratios are obtained and maintained.

**NOTE: IMPROPER INJECTION RATIOS COULD BE HARMFUL TO PERSONAL HEALTH OR EQUIPMENT.**

## INSTALLATION

- Your injector is packaged with all components ready for installation. The picture below shows the items that should be included with your purchase.



Be sure and remove the red caps at the inlet and outlet openings and at the suction tube fitting opening. Each unit is shipped with a little water in it as it is tested before shipping. The red caps prevent leakage during shipment, but must be removed prior to installation. It is best to save the red caps so that if you need to store the unit or take it off line, you can plug the openings to keep the water in and prevent the o-rings from drying out.



- **After I take the red plugs out, what then?**

Once, the red plugs are out, you should screw the adapters that are enclosed onto each end of the injector as shown in the photo at right.



- **Where should I install my injector?**

Because it is driven by the water flow, the Advantage injector can be located anywhere in a cold water line. The injector's location should be selected to provide a safe but accessible place for the solution container, away from children or normal traffic, to avoid spillage and potential contact with hazardous chemicals in the solution container. **Figure 4 on page eight** shows the dimensions of the unit for calculating the area needed for installation.

- **What tools will I need to install my injector?**

When installing into a PVC line you will need: Pipe cutters, pipe wrench, PVC glue and primer, Teflon tape and your fittings.

- **What additional equipment is required for a proper installation?**

Dosmatic recommends that you install a 140-mesh in-line water filter in front of your injector. Depending upon your water condition, it may be necessary to install larger mesh filters in series between the water source and the 140-mesh filter.



- **A back-flow preventer is required by all city ordinances** to prevent back up of solutions into drinking lines and potable water supplies in the event of a water line break. Dosmatic does not recommend one back-flow preventer over another. It is the user's responsibility to check with local authorities to ensure their system complies with all regulations.
- **An anti-siphon valve** is recommended to prevent solution from being siphoned out when the upstream valve is shut off. The anti-siphon valve must be installed 6" above the highest downstream piping.
- **A by-pass set-up** will allow you to have a way to take the unit off-line for maintenance or storage when not in use.
- **Pressure regulators and gauges** in your system, such as EC (electrical conductivity) meters or TDS (total dissolved solids) meters are also helpful to verify the accuracy of the unit on a monthly basis.
- **A water hammer arrester** is highly recommended if you are operating quick closing, solenoid valves, pneumatic valves or even hand-operated ball valves on your watering system.
- **See page six** for a typical installation **and page seven** for a typical tank-feed installation.

- **LABEL WATER LINES:** Water passing through the injector and down stream from it will contain additive from the solution container. Label all water lines, valves and connections with a warning that the water supply contains additive. If the solution being injected is **not** compatible for drinking water, label all water lines as follows:

**WARNING – NOT FOR HUMAN CONSUMPTION !**

- **What water line temperature and pressure should I maintain?**

Install the Advantage injector in a cold water line - between 32 degrees Fahrenheit or 0 degrees Celsius and 100 degrees Fahrenheit or 38 degrees Celsius - with a water pressure applicable for the model you are installing. Pressure should be regulated to the lowest pressure required for final delivery. A water pressure greater than recommended for the injector can cause permanent damage to the injector. (Refer to the specifications for the model you are installing)

- **What are the arrows on the injectors for?**

The arrows on the injector body indicate direction of water flow and are for your convenience in assuring a proper installation. Install the A15 with the arrow *pointing* to the outlet side as shown in the photo here.

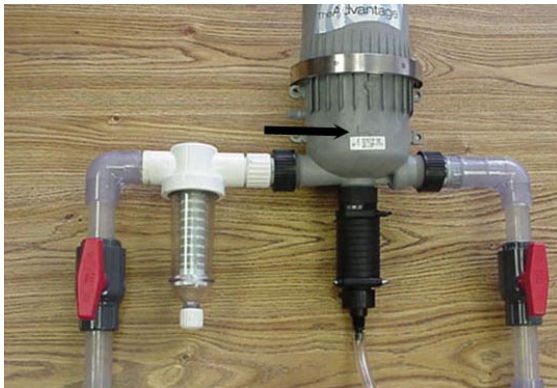

- **Do I really need to install an inlet water filter?**

Yes. Install a 140-mesh filter on the inlet side of the injector to prevent debris from entering the motor of the injector and to prolong the working life of the unit. Installing a filter is especially important if your water source is from a well or pond. Dosmatic carries spin-down filters that can be ordered with your injector. Failure to use an inlet filter will void any warranty.

➤ **Sand Filter Requirements:** Install the injector only on cold water supplies that are free of all sand and grit. These abrasive substances will shorten the effective life of the injector. If your water supply contains sand, a sand separator should be installed at the water source. A series of filters can also be used between the water source and the 140 mesh (104 micron) inlet filter directly preceding the injector.

- **How high above the solution container can I install my injector?**

Dosmatic recommends no more than a 15' (4,6 meters) vertical hose and no more than a 50' (15,2 meters) horizontal hose from the solution container to the injector.

- **MOUNTING THE INJECTOR:**

- Mount the injector vertically and no higher than 15 feet (4,6 meters) above stock solution container.
- Use the mounting bracket supplied to rigidly attach the injector to a solid structure such as a wall.
- The Injector can also be plumbed directly into the water line with standard pipe fittings. (Fig. 1, page 5).





- To cut pipe: Turn off water pressure and drain water line. Obtain necessary plumbing fittings and valves to install the injector into your cold water line.
- **CAUTION:** Be sure to install your water supply to the injector connector in the direction of the water flow.

• **CONNECT SOLUTION CONTAINER:**

- Install Suction Tubing #25 onto the Hose Barb located at the lower end of the injector as show in the photo here.
- If your solution container has a cover, insert the Suction Tubing filter through the cover by drilling a hole, leaving the cover to prevent debris in the solution. In all cases, fasten the Suction Tube securely as it will move during operation of the injector.
- Put enough water in the Solution Container to cover the solution filter by at least 2 inches (**Fig. 2, pg. 6**) as shown in photo below. Add food coloring to water to aid in testing that the injector has been properly installed as you proceed to “**Start-up Procedures.**”



- **NOTE:** The solution filter may float until the suction hose to the injector is primed.
- **NOTE:** The solution filter should be kept 2” from the bottom of the container to prevent debris from collecting in the filter.

• **SHUT-OFF VALVE:**

- Install the injector as shown in the “Suggested Installation” drawing on **page six** and always control the unit using the valve on the *exiting* water line. Using the inlet side valve as a shut-off valve could cause full strength solution to siphon into the feed line.

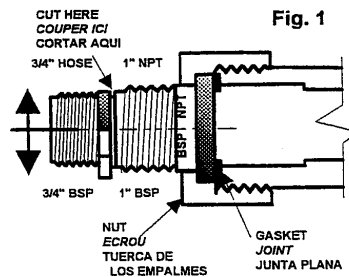

Fig. 2

# SUGGESTED INSTALLATION

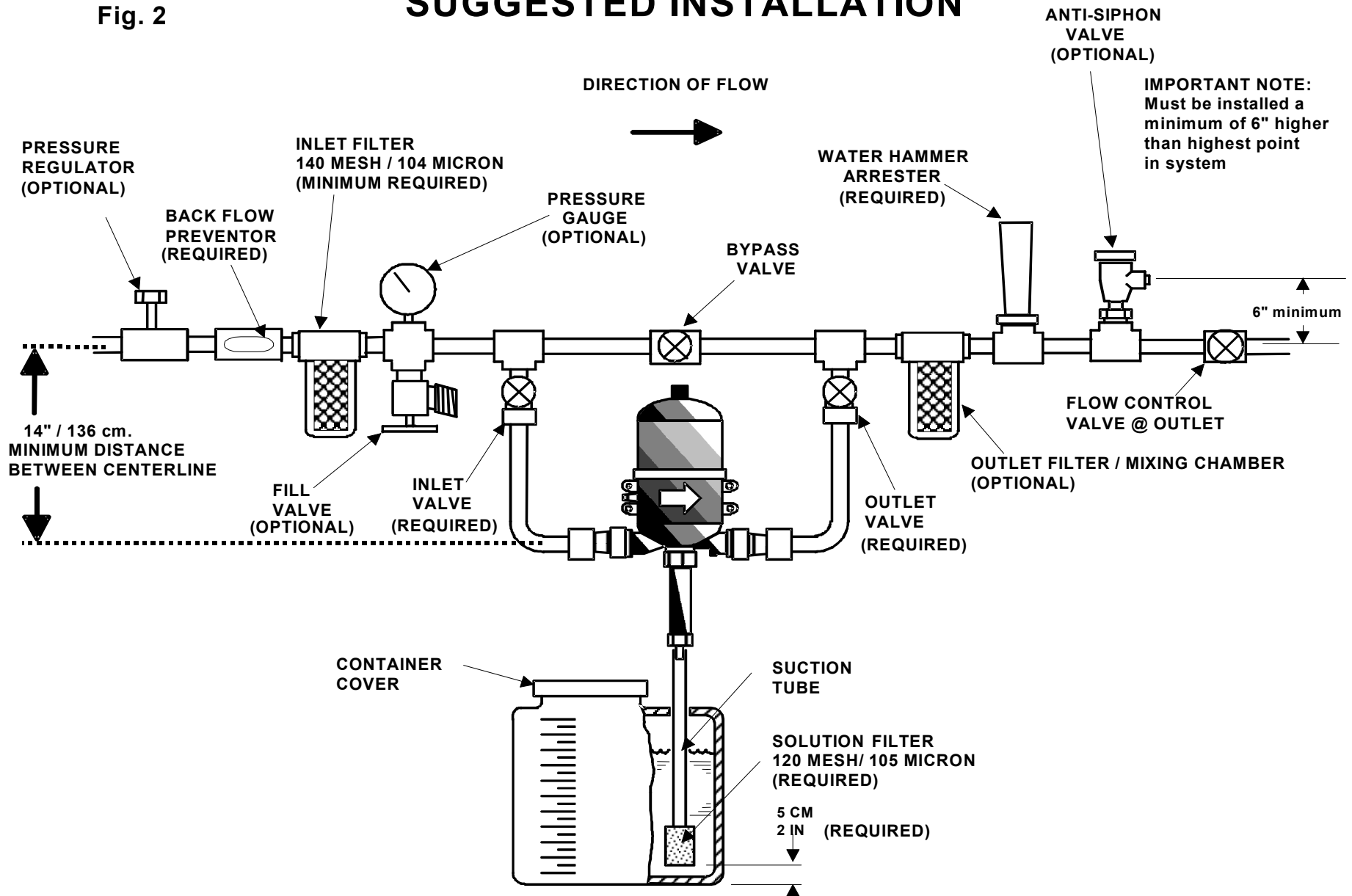

Fig. 3

### GRAVITY (TANK FEED) INSTALLATION

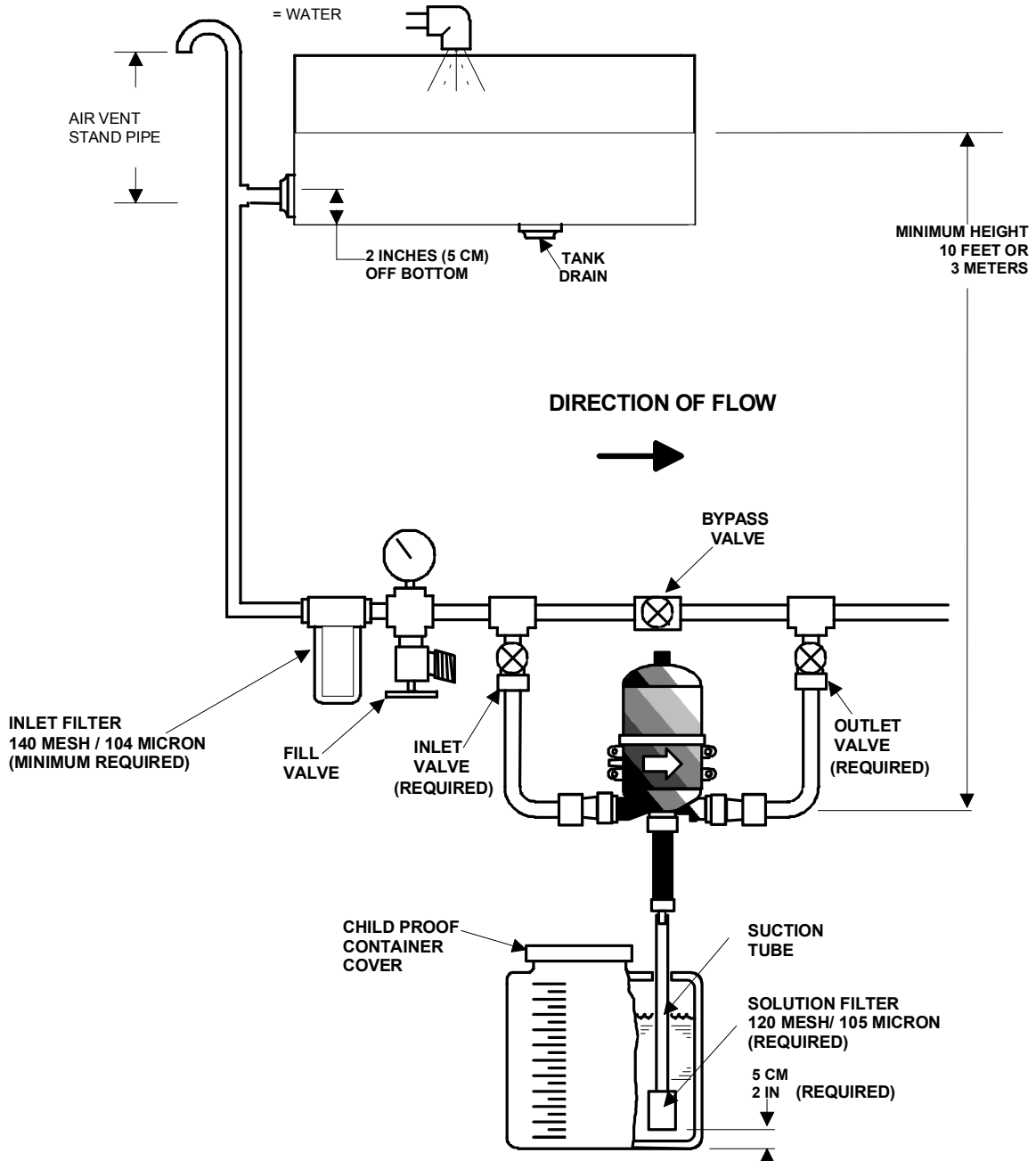
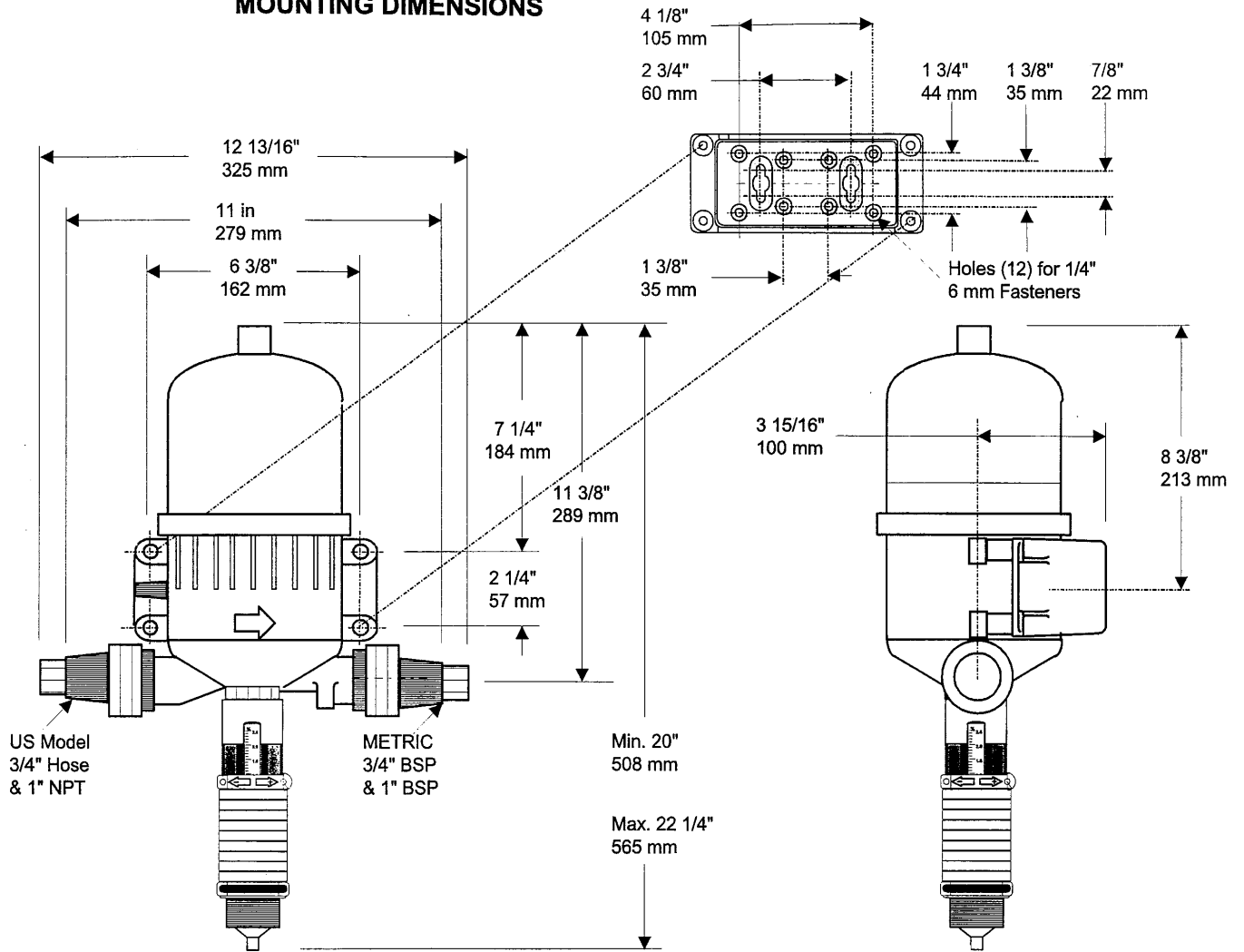



Fig. 4

**MOUNTING DIMENSIONS**



## START-UP PROCEDURES

- Close inlet and outlet valves and open bypass valve.
- Slowly turn on main water pressure until water flows between 5 and 15 GPM (19 to 57 LPM) or 30 PSI (2 bar) maximum to fully prime the suction hose.
- Slowly open the water supply valve and all valves downstream of injector to release entrapped air.
- Carefully open inlet valve allowing water to enter and pressurize the injector.
- Open outlet valve and close bypass valve. Water will now flow through the injector, and a continuous sound will be omitted from the injector as water passes through it.
- Check for system leaks and correct if necessary. Adjust the outlet valves downstream from the injector, if necessary. The colored water from the solution container (**see “Connect Solution Container” on page five**) should now be going up the solution tubing and flowing through the injector. Outlet water should have trace amounts of the food coloring additive. Be sure the bypass valve is tightly closed.

## CHEMICAL MIXING

### • SOLUTIONS:

- Pour clear solution into permanent solution tank.
- To promote complete dissolving, use WARM WATER, less than 120° F (49° C). Undissolved particles will increase the maintenance frequency of the injector.
- Allow the water to cool below 100° F (38° C) before injecting.
- **CAUTION:** Mix solutions in clean, well-rinsed containers. Clean the solution container often. It may be necessary to mix all stock solutions in a separate container allowing any precipitate from the mixture to settle to the bottom of the container.

### • AVOID CONTAMINATION:

- Use only clean FILTERED water. The water and solution mix will be added to the water supply which will only be as pure as the mixture in the solution tank. Contaminants, such as dirt, debris and other substances, that are allowed to enter the solution container will be pumped into the water line and can cause the spread of disease and excessive wear to the injector. Therefore, it is imperative to keep the solution container covered and free of all contaminants.

### • ADJUSTING INJECTOR RATIOS:

- **READ AND FOLLOW CHEMICAL MANUFACTURER’S INSTRUCTIONS.** Using the chemical manufacturer’s recommendations, determine the amount of chemical to mix in the solution tank and the proper ratio setting for the injector.
- Check the setting on your injector by ensuring that the top of the cylinder sleeve is directly under the desired setting. Adjust the setting of additives as required by the instructions on the label of the additive being injected (**Fig. 5, pg. 10**). Improper settings could result in ineffective performance of additive.
- **NOTE:** If the viscosity of the solution being injected is greater than 50 centipoise, the ratio setting may need to be calibrated for the higher viscosity. Dosmatic injectors are calibrated with water at 37 centipoise.



## CHLORINATION

- Use softened water in solution tank, if possible. When chlorine mixes with hard water the calcium from the hard water will precipitate.
- Add one (1) ounce of liquid chlorine (5 1/4%) per gallon of water in the solution tank
- Run water to the farthest point in the water system, and test for chlorine residual with a test kit. A 0.5 to 1.0 ppm of **free chlorine** is a safe effective level of chlorine in drinking water. When chlorine interacts with organic material in the water lines, its potency is decreased. Dosmatic recommends starting with a higher level of chlorine at the outlet of the injector to achieve 0.5 to 1.0 ppm at the farthest point in the water system.

## USING YOUR INJECTOR

### • How do I adjust the ratio setting and what do the numbers mean?



- To adjust the ratio setting, pull out the upper pin and simply rotate the ratio adjuster until the desired setting is directly above the top edge of the ratio adjuster (**See Fig. 5 below**).
- NOTE: Do not use the holes that appear when you pull the pin out as a window for setting the ratio!
- Numbers appear on the left and right sides of the outer cylinder on most models. The left-hand column lists an injection percentage, and the right hand column gives the ratio of solution being injected to water passing through the unit. These numbers are really the same. For example, the number on the left-hand side is 2.5 which equals 2.5%. Its equivalent to the right is the number 40, which is the denominator of the ratio 1:40. The number 1 divided by 40 equals .025 or 2.5% and so on.
- Remember, when determining the setting for your ratio adjuster, always use common units of measure for both solution and water – e.g. gallons to gallons or ml to ml.

(Fig. 5)

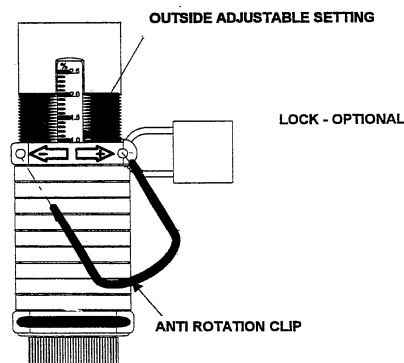

### • How do I calculate my ratio setting and ppm?

- When using a water-driven injector to dispense the chemical, it is imperative that the chemical be water-soluble.
- If you have determined that the product is water soluble, the next step is to identify the chemical's solubility limit. **If product is added beyond the solubility limit, it will not dissolve, but will settle out in the solution container.** This causes clogging in the injector, and the proper dosage of solution will not be dispensed. Premature failure of the seals, o-rings, dosage piston, inner cylinder and check poppet can also occur.

- The next step is to determine the amount of chemical required for the application.
  - ◆ The user must decide what parts per million (ppm) of chemical is right for the particular application. Neither the chemical manufacturer nor the injector manufacturer is responsible for specifying a ppm for the user's application.
  - ◆ The best way to determine fertilizer needs is to have the soil or foliage tested. Contact your local agricultural extension agency or other expert for assistance. For other non-horticultural applications, contact an authority for the application.
- Once you know the desired ppm, you can usually find a precalculated chart on the back of the chemical bag or container listing the equivalent ratio, percentage or ounces per gallon. *If you don't have a chart, you can still determine how to correctly mix the chemical to the amount of water in your container.* The following outlines ways to figure the amount of chemical injected per gallon of water.
  - ◆ **Method A** gives a formula for finding the pounds of chemical or fertilizer per one gallon of water delivered to the plants, if you know the ppm required.
  - ◆ **Method B** outlines how to use the formula from Method A to calculate changing injection ratios once your solution is mixed.

For both methods four factors are critical: 1) the desired ppm or the weight of the chemical added; 2) the % of active ingredient; 3) the injection ratio and 4) the tank size or gallons.

### **Method A:**

To determine the pounds (or ounces) required if you know the ppm of chemical per gallon of water needed follow the steps below.

- ✓ The following example is a fertilizer application, but the principle applies to any chemical solution.
- ✓ **Example:** You want to fertigate at 150 ppm of nitrogen using a 20-10-20 soluble fertilizer. You have your injector set at a 1:100 ratio. How much fertilizer should be put in the solution tank?

$$\text{Ounces of fertilizer} = \frac{150 \text{ ppm} \times 100}{75 \times 20}$$

**Answer** = 10 ounces of fertilizer per gallon of water.

- ✓ The 150 = **the recommended ppm for the crop**; the 100 = **the injection ratio**; the 20 = **the % of active ingredient**; the 75 is a constant conversion factor used for finding ppm (1 ounce of any 100 percent soluble fertilizer or chemical in 100 gallons of water always equals 75 ppm). **The tank size or gallons is one gallon here.** If you have a tank size of more than one gallon, multiply your answer by the number of gallons.

### **Method B:**

To calculate what injection ratios would provide other ppms of the same chemical mixture, follow the steps below.

- ✓ If mixing the fertilizer for various ppms, you will need to choose one ppm as your base for a 1:100 injection ratio and then calculate the other ratio settings for the other ppms.
- ✓ **Example:** If you have various fertilizers such as 20-20-20, 10-52-17, etc., Choose nitrogen (the second number) as the chemical to determine your ppm.

- ✓ **Formula:** recommended ppm x injection ratio/75 (constant) x % fertilizer. Choose 20-20-20 and solve for 50 ppm, 100 ppm and 200 ppm.
  - ❖ **Select 100 ppm as your base.** You could choose 50 or 200, but choosing 100 simplifies calculations. Also, choose 1:100 as your injection ratio. You could choose any ratio setting to find the ounces per gallon needed, but choosing 1:100 makes it much easier to calculate your settings.

$$\frac{100 \text{ ppm} \times 100}{75 \times 20} = 6.67 \text{ oz per gallon}$$

**Answer = 6.67 oz per gallon to obtain 100 ppm at a 1:100 ratio setting.**

If you are using an 8 gallon container, multiple 6.67 oz. X 8 = 53.3 oz or 3.33 lbs. per 8 gallons and so on for other gallon containers.

- ❖ **Solve for Ratio at 50 ppm.** Since you now know that you mixed 6.67 oz per gallon of water, the missing variable is the injection ratio or setting that you need to mix the solution at 50 ppm, so R = injection ratio.:

<b>Step 1</b> $\frac{50 \text{ ppm} \times R}{75 \times 20} = 6.67 \text{ oz.}$	<b>Step 2</b> $\frac{50R}{1500} = 6.67$	<b>Step 3</b> $50R = 6.67 \times 1500$	<b>Step 4</b> $50R = 10,005$	<b>Step 5</b> $R = \frac{10,005}{50}$
--	--	---	---------------------------------	--

**Step 6**  
R = 200  
**You now know that you need to adjust your ratio from 1:100 to 1:200**

- ❖ **Solve for Ratio at 200 ppm.** Follow the exact steps above, but substitute “200” ppm for “50” ppm.

- **You can increase or decrease your ppm by adjusting the ratio of the injector while it is in operation.** The Advantage™ injector allows you to simply leave the solution container as it is and adjust the injector ratio instead.
  - ◆ Below is an example of how to adjust your ratio to increase your ppm. Although the example is for horticulture, the method holds true for animal health and industrial applications.
  - ◆ **Example:** You have added 13.4 ozs. of fertilizer (20-20-20) to one gallon of water using a 1:200 injector ratio to achieve **100 ppm** of Nitrogen. You have a 50 gallon tank so you multiply 13.4 ozs. x 50 = 670 ozs. or 41.875 lbs. and add this to 50 gallons of water in your solution tank. Now your plants are maturer, and you want to fertigate at a ppm of **200**. You simply adjust the injector ratio from 1:200 (or 0.5%) to 1:100 (or 1%) and your ppm is now 200! *(Remember, the higher the ppm or % required, the lower the ratio number).*

- **Do I need to calibrate my injector?**

Yes. Regular maintenance of the o-rings and dosage piston (wear parts) will help prevent deviations from the selected dosage. Because all injectors are a mechanical piece of equipment, wear on parts is inevitable over time, depending upon the amount of use. Electro Conductivity (EC) or Total Dissolved Solids (TDS) meters can be used to verify accuracy.



- **Do I need to bleed or purge the air on my injector?**

No. There should be no reason to bleed the injector, as the water flow will force air through the line. In some cases where a tank feed, low pressure or low flow system is installed with the injector being the highest point in the watering system, a low flow might cause air to be trapped in the line. In that case, you may slowly and carefully unscrew the top air bleeder slightly and push down until water squirts out.



Extreme caution should be taken when attempting this, and you should never unscrew the bleeder all the way off.

- **What chemicals can I use in my injector?**

Most chemicals, including acids, can be proportioned with Dosmatic injectors. Some concentrations of sanitizers and deodorizers can harm the Noryl bodies. Special Polypropylene bodies can be ordered to accommodate these applications. With certain chemicals, such as iodine and chlorine (5% or more solutions), a remote injection kit is recommended. Contact Dosmatic at (800) 344-6767 or (972) 245-9765 or e-mail [info@dosmatic.com](mailto:info@dosmatic.com) for assistance with your particular solution.

- **Can I inject two or more chemicals at the same time?**

Yes. To use two or more chemicals at the same time, you can install injectors in a series.

- When installing in a series, you should use a remote injection kit to protect the injectors if the chemical is abrasive or if the chemicals are not compatible. If the series is a two-unit series, then only the first injector needs a remote injection kit.
- If a remote injection kit is not used with a series installation, then the first chemical solution becomes the inlet water for the second injector, and, depending upon the chemical, this could damage the second (or subsequent) injector motors.
- If using acid to neutralize water pH, *you should install your piping so that there is approximately 3 feet from the last injector to the remote by-pass point.*



Caution: Combining two chemicals in the solution tank can produce a chemical reaction that could damage the injector or even an explosion resulting in personal injury.

(Fig. 6)

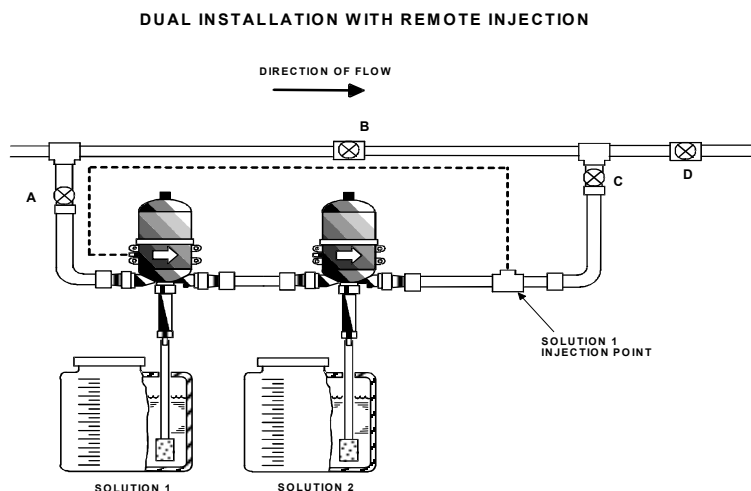

- **Can I use hot water to dissolve my chemical?**

- *Some chemicals may be damaged with hot water so be sure to check with your chemical manufacturer before adding hot water.*
- Dissolve the chemical in warm water, if necessary and if the chemical will not be damaged, but allow the water to cool before using.
- When using a water-soluble chemical, make sure it is thoroughly dissolved before opening the inlet water and starting the injector.



**Caution:** Failure to thoroughly dissolve the chemical being injected will cause premature wear to the dosage piston and the cylinder.

- **How do I store my injector?**

- Rinse the lower end with fresh soapy water.
- Remove the injector from the water line.
- Remove and clean the lower end assembly.
- Store the injector and the lower end in a five-gallon bucket of mildly chlorinated water to prevent drying of the interior parts.



**Caution:** Do not store the injector at temperatures below freezing. Do not allow the lower end to dry out at any time.

## **MAINTENANCE**

The Advantage injector has been designed and built to inject liquid solutions with a minimum of maintenance. However, solutions being injected by the unit may not be fully dissolved or the water supply may be contaminated, leaving deposits, residue and precipitates in the injector that require attention to provide maximum dependable service. The degree to which this occurs will vary depending upon the solutions used and the cleanliness of the water supply.

By performing the following maintenance procedures, your injector will be ready to serve your needs reliably and accurately.

- **What preventative maintenance do you suggest?**

- **Clean inlet filter:** Clean or replace water filter as required to reduce pressure loss and optimize the life of the injector. Always provide the injector with clean filtered water.
- **Keep solution and solution filter clean:**
  - ◆ Keep the solution container covered to prevent dirt, flies, feathers, leaves or other air-borne debris from entering container.
  - ◆ Rinse container thoroughly and often.
  - ◆ Mix solution daily or more often, if necessary.
  - ◆ Use FILTERED WATER when filling the container.
  - ◆ Clean your solution filter regularly with warm, soapy water.
- Dosmatic recommends that you change the o-rings and dosage piston (wear parts) at least once a year, preferably every six months, depending upon usage.



**Caution:** Do not mix different solutions together as they might react and cause a precipitate.

**Caution:** Never operate the injector at a water pressure or water flow outside the recommended range for the model installed.





- **If the injector is used infrequently, rinse the injector after each use:** Put dip tube into 1 qt. (1 liter) or more of fresh filtered water and operate injector to suck water through the lower end, thereby rinsing out additive. Additive allowed to remain in an inactive injector can dry out and foul or damage lower end at the next start up. This procedure is not needed when the injector is in continuous operation.



Caution: Do not allow the lower end to dry out at any time.

- **My solution filter keeps clogging. Can I just remove it?** No, do not remove this filter.
  - Position filter at least 2" (50 mm) from the bottom of the solution container to prevent debris from clogging the filter and stopping the injector from functioning. If your solution is not thoroughly dissolved, your filter may become clogged.
  - Check to be sure that the chemical is completely dissolved. You may need to add an agitator to keep the solution from settling.
  - Keep the solution container covered so that debris does not contaminate your solution and clean the solution container occasionally to prevent dirt and scale build-up. Inspect the solution strainer each time new solution is added.
  - Clean the filter as frequently as necessary by washing in fresh water. Remove the suction tube and run water backwards through the filter.

- **What lubricant should I apply to the o-rings of my injector?**

Reapplying silicone is not necessary unless an extended storage period is anticipated. The Advantage injector is shipped with a thin coat of silicone around the seals as a precautionary measure before the injector is put in use. Call Dosmatic at (800) 344-6767 or e-mail [info@dosmatic.com](mailto:info@dosmatic.com) if you have any questions.

**Caution: Never use petroleum based lubricants such as Vaseline, baby oil, WD 40, motor oil, etc.** on the O-rings or any part of the injector as this can cause a chemical reaction. damage to O-rings or particles to adhere and clog or damage the injector.

## TROUBLE SHOOTING

- **My injector is not working and is not clicking. What do I do?**

Advantage injectors should make a gentle clicking noise when in operation. If it is **not clicking** and your unit has just been installed:

- Did you remember to remove the red plugs at the inlet and outlet openings?
- Is the water pressure appropriate for the model injector?
- Is the water flow in the direction of the arrow located on the injector body?
- Is the water source turned on?
- If the injector is still not clicking, do not open the upper body. Call the Dosmatic Technical Department at +1 (800) 344-6767 for further assistance.

- **If your injector it is not clicking and has been working previously:**

- Is the injector working at high water flows but not at low water flows? If so, then the problem may be a worn o-ring (#17) located in the lower area of the injector body. Inspect and replace the o-ring, if necessary.
- Has the injector been disconnected from the water source for longer than 30 days? If so, submerge the injector in water for 24 hours so that the sealing parts can reabsorb water and swell back to the proper size.
- If the injector is still not clicking, do not open the upper body. Call the Dosmatic Technical Department at +1 (800) 344-6767 for further assistance.



- **My injector is clicking, but it is not drawing solution. What do I do?**
  - Inspect and clean the solution filter. Be sure it is suspended at least 2" (50 mm) off the bottom of the solution container.
  - Are the dosage piston or o-rings worn? The dosage piston and o-rings are wear parts that should be inspected and replaced every 6 – 12 months to maintain accurate proportioning.
  - Follow the "Wear Part Maintenance" steps below.

**WEAR PARTS MAINTENANCE**

- Be sure to first **rinse the injector with clean water**. The lower end may contain full strength solution that could be dangerous. Read the warning labels on the containers of chemicals being injected and observe any precautionary statements.
- To rinse out additive, put suction tube into a one gallon (4 liter) or more of fresh filtered water and run water through the injector to suck water through the lower end.
- Turn off inlet water valve and relieve the water pressure in the injector water line.
- Turn on the bypass valve, if necessary.

**Advantage A15 - 4ml Model**

ccw = counter clock wise

cw = clock wise

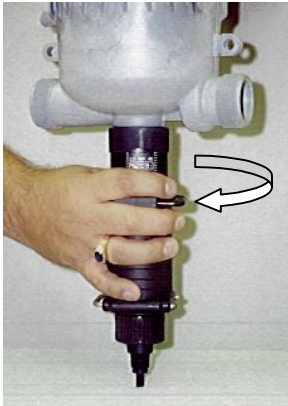

**Step 1 –** Unscrew the lower end assembly (cw) and separate it from the body of the injector. Set aside.

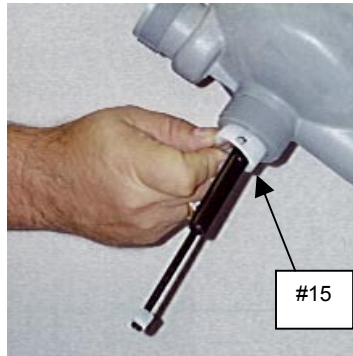

**Step 2 –** Using your hand or a pocket screwdriver, remove the o-ring retainer (#15) that may still be in the opening of the body. If desired, you may remove the shaft assy. first (Step 3)

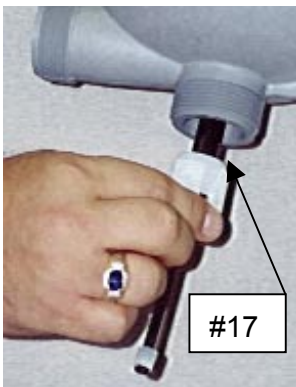

**Step 3 –** Remove the shaft assembly (#51) from the body of the injector by turning a ¼ turn (cw). Remove the o-ring (#17) that was held in place by the o-ring retainer

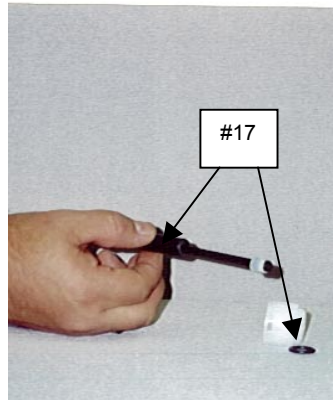

**Step 4 –** Replace the shaft assembly (#51) with a new one, placing the o-ring retainer (#15) on the shaft assembly. Place a new o-ring (#17) on top of the o-ring retainer.

**WEAR PARTS MAINTENANCE (cont.)  
Advantage A15 - 4ml Model**



**Step 5** - Reinsert the shaft assembly (#51) into the body and twist ¼ turn (ccw) until you feel it lock into place. Adjust the o-ring (#15) retainer until it locks into place. Push it firmly up into the body.

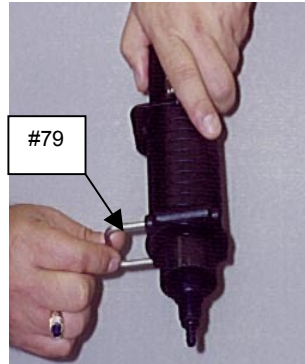

**Step 6** – Remove the bottom pin (#79) from the lower end assembly.

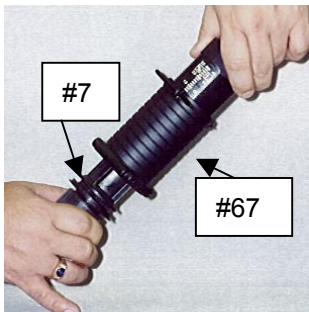

**Step 7** – Pull the inner cylinder (#7) assembly from the outer cylinder (#67). Inspect the #64 o-ring (see Step 8) of the inner cylinder and replace if necessary.



**Step 8** – Unscrew (cw) the suction tube fitting from the inner cylinder, and rinse the fitting under running water to remove debris. Set aside

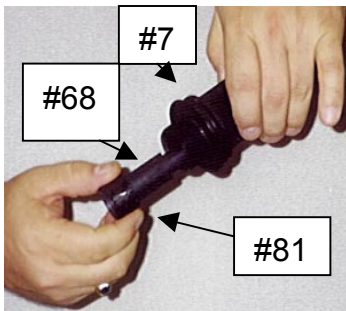

**Step 9** – Using a blunt object, push the smaller cylinder (#68) from the inner cylinder (#7) and pull out. Inspect the #81 o-ring and replace if necessary.

**Step 10** – Clean, dry and inspect both the smaller cylinder and the inner cylinder for scratches and cracks (do not dry out the o-ring). If either are damaged, replace them. Reinsert the smaller cylinder into the inner cylinder. Screw (ccw) the suction tube fitting back onto the inner cylinder assembly.

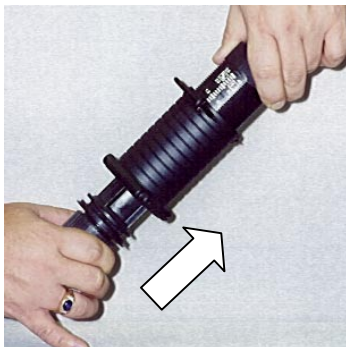

**Step 11** - Reinsert the inner cylinder into the lower end. Reinsert the bottom pin.



**Step 12** – Screw (ccw) the lower end back onto the unit opening. Be careful that the shaft, o-ring and o-ring retainer are securely in place.

- If the injector will be used immediately, ensure that the outlet valve is on, turn the by-pass valve off and slowly open the inlet valve to the injector.
- If the injector will not be used for two weeks or more, close the outlet valve, slowly open the inlet valve to fill the unit with water, then close the inlet valve and open the bypass valve.



## WEAR PARTS MAINTENANCE (cont.)

### Advantage A15-2.5% Model

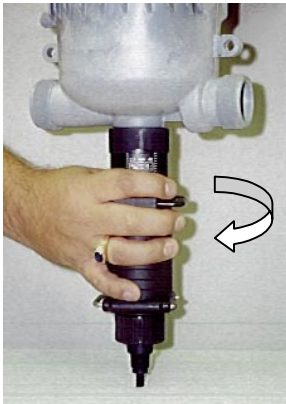

**Step 1** – Unscrew (ccw) the lower end assembly and separate it from the body of the injector.

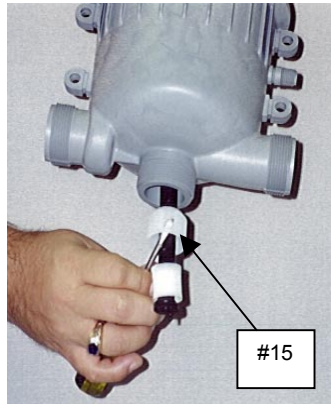

**Step 2** - Using a pocket screwdriver or other tool, remove the o-ring retainer (#15) that is still in the opening from which the shaft assembly was pulled. If desired, you may remove the shaft assy. first (Step 3)

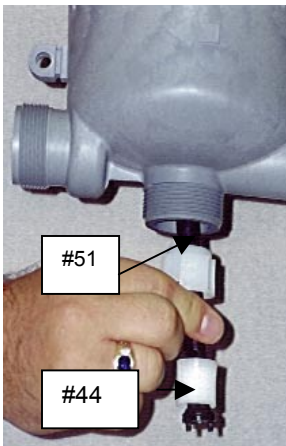

**Step 3** - Remove the shaft assembly (#s 44, 51) from the body of the injector by turning a ¼ turn (ccw). Set the o-ring retainer aside.

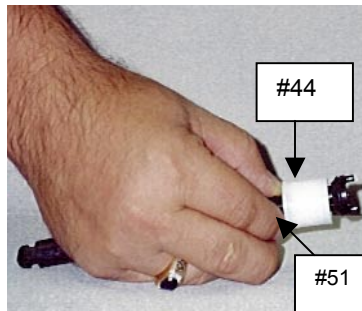

**Step 4** - Remove the dosage piston (#44) by depressing the two “ears” of the shaft (#51) at one time, removing the piston upwards. Inspect the shaft for scoring. If scored, replace with a new one.

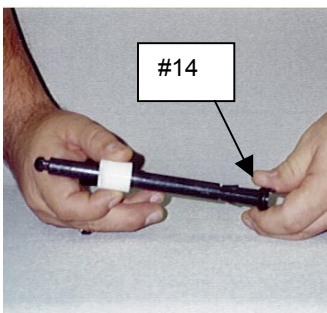

**Step 5** – If the o-ring on the shaft (#14) is worn, remove and replace it. Place a new dosage piston on the shaft **being sure to place the flared, thin edge up**. Place the o-ring retainer onto the shaft assembly.

**Step 6** - Remove the o-ring (#17) that was held in place by the o-ring retainer. Place a new o-ring on top of the o-ring retainer on the shaft assembly.

**WEAR PARTS MAINTENANCE (cont.)**  
**Advantage A15-2.5% Model**



**Step 7** - Reinsert the shaft assembly into the body and twist ¼ turn (ccw) until you feel it lock into place. Adjust the o-ring retainer with o-ring until it locks into place. Push it firmly up into the body.

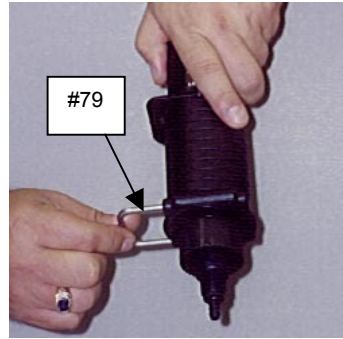

**Step 8** - Remove the bottom pin (#79) from the lower end assembly.



**Step 9** – Pull the inner cylinder (#7) assembly from the outer cylinder (#67). Inspect the #64 o-ring (see Step 10) of the inner cylinder. Replace if necessary.



**Step 10** – Unscrew (cw) the suction tube fitting (Kit D-#s 10-13, 71, 80) from the inner cylinder, and rinse the fitting under running water to remove debris. Set aside

**Step 11** – Clean, dry and inspect the inner cylinder for scratches and cracks (do not dry out the o-ring). If damaged, replace it. Screw (cw) the suction tube fitting back onto the inner cylinder assembly.

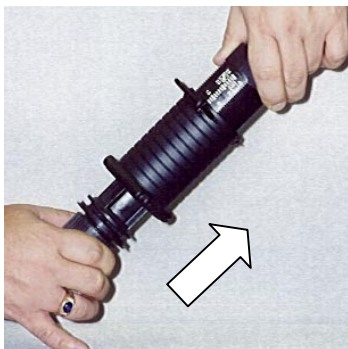

**Step 12** - Reinsert the inner cylinder into the lower end. Reinsert the bottom pin.



**Step 13** – Screw (ccw) the lower end back onto the unit opening. Be careful that the shaft, o-ring and o-ring retainer are securely in place.

- If the injector will be used immediately, ensure that the outlet valve is on, turn the by-pass valve off and slowly open the inlet valve to the injector.
- If the injector will not be used for two weeks or more, close the outlet valve, slowly open the inlet valve to fill the unit with water, then close the inlet valve and open the bypass valve.

## REORDERING DOSMATIC PRODUCTS

- To reorder Dosmatic units, contact your local Dosmatic Distributor and order using the following part numbers and criteria.

### SPECIFICATIONS FOR DOSMATIC INJECTORS

Model	Part # NPT	Part # BSP	Flow Rate Minimum	Flow Rate Maximum	Feed Ratio Minimum	Feed Ratio Maximum	Operating Pressure	Inlet/Outlet
A10-1% Medicator	112340	112341	0.03 gpm 0,11 lpm	12 gpm 45 lpm	0.2% 1:500	1.0% 1:100	6.0 – 100 psi 0,41 – 6,9 bar	3/4" npt 3/4" bsp
A10 – 1%	112300	112301	0.03 gpm 0,11 lpm	12 gpm 45 lpm	0.2% 1:500	1.0% 1:100	6.0 – 100 psi 0,41 – 6,9 bar	3/4" npt 3/4" bsp
A10 – 2.5%	112352	112353	0.03 gpm 0,11 lpm	12 gpm 45 lpm	0.5% 1:200	2.5% 1:40	6.0 – 100 psi 0,41 – 6,9 bar	3/4" npt 3/4" bsp
A10 – 2.5% Mobile	011607	011607	0.03 gpm 0,11 lpm	12 gpm 45 lpm	0.5% 1:200	2.5% 1:40	6.0 – 100 psi 0,41 – 6,9 bar	3/4" npt 3/4" bsp
A10 – 5%	112355	112356	0.03 gpm 0,11 lpm	12 gpm 45 lpm	1.0% 1:100	5.0% 1:20	6.0 – 85 psi 0,41 – 6,0 bar	3/4" npt 3/4" bsp
A15 – 2.5	113004	113504P	0.04 gpm 0,16 lpm	15 gpm 57 lpm	0.2% 1:500	2.5% 1:40	4.0 – 85 psi 0,27 – 6,0 bar	3/4" hose/1" npt 3/4" bsp/1" bsp
A15 – 4ml	113524	113525	0.04 gpm 0,16 lpm	15 gpm 57 lpm	0.025% 1:4000	0.4% 1:250	4.0 – 85 psi 0,27 – 6,0 bar	3/4" hose/1" npt 3/4" bsp/1" bsp
A20 – 2.5%	113001	113501P	0.04 gpm 0,16 lpm	20 gpm 76 lpm	0.2% 1:500	2.5% 1:40	5.0 – 100 psi 0,34 – 6,9 bar	3/4" hose/1" npt 3/4" bsp/1" bsp
A20 – 10%	113008	113508	2.0 gpm 7,6 lpm	20 gpm 76 lpm	2.0% 1:50	10.0% 1:10	5.0– 55 psi 0,33 – 3,8 bar	3/4" hose/1" npt 1" bsp/1" bsp
A30 – 2.5%	113002P	113502P	0.25 gpm 0,95 lpm	30 gpm 114 lpm	0.2% 1:500	2.5% 1:40	5.0 – 100 psi 0,34 – 6,9 bar	3/4" hose/1" npt 3/4" bsp/1" bsp
A30 – 2.5% Mobile	011807	011807	0.25 gpm 0,95 lpm	30 gpm 114 lpm	0.2% 1:500	2.5% 1:40	5.0 – 100 psi 0,34 – 6,9 bar	3/4" hose/1" npt 3/4" bsp/1" bsp
A30 – 5%	113007P	113507P	0.25 gpm 0,95 lpm	30 gpm 114 lpm	0.4% 1:250	5.0% 1:20	5.0 – 100 psi 0,34 – 6,9 bar	3/4" hose/1" npt 3/4" bsp/1" bsp
A30 – 4ml	113005P	113505P	0.25 gpm 0,95 lpm	30 gpm 114 lpm	0.025% 1:4000	0.4% 1:250	5.0 – 100 psi 0,34 – 6,9 bar	3/4" hose/1" npt 3/4" bsp/1" bsp
A40 – 2.5%	113003P	113503P	0.50 gpm 1,89 lpm	40 gpm 151 lpm	0.2% 1:500	2.5% 1:40	5.0 – 100 psi 0,34 – 6,9 bar	1 1/2" slip 50 mm slip
A40 – 4ml	113006P	113506P	0.50 gpm 1,89 lpm	40 gpm 151 lpm	0.025% 1:4000	0.4% 1:250	5.0 – 100 psi 0,34 – 6,9 bar	1 1/2" slip 50 mm slip
A80 – 2.5%	011808	011808	1.0 gpm 3,8 lpm	80 gpm 303 lpm	0.2% 1:500	2.5% 1:40	5.0 – 100 psi 0,34 – 6,9 bar	2" slip 63 mm slip
A120 – 0.5% Single	114031	N/A	15 gpm 57 lpm	100 gpm 379 lpm	0.1% 1:1000	0.5% 1:200	15 – 120 psi 1,03 – 8,3 bar	2" npt
A120 – 1% Twin (using 1 injector or 2 injectors for different chemicals)	114032	N/A	15 gpm 57 lpm	100 gpm 379 lpm	0.1% 1:1000	0.5% 1:200	15 – 120 psi 1,03 – 8,3 bar	2" npt
A120 – 1% Twin (using 2 injectors for 1 solution)	114032	N/A	15 gpm 57 lpm	100 gpm 379 lpm	0.2% 1:500	1.0% 1:100	15 – 120 psi 1,03 – 8,3 bar	2" npt
A120 – 1% Single	114033	N/A	15 gpm 57 lpm	100 gpm 379 lpm	0.5% 1:200	1.0% 1:100	15 – 120 psi 1,03 – 8,3 bar	2" npt
A120 – 2% Twin (using 1 injector or 2 injectors for different chemicals)	114034	N/A	15 gpm 57 lpm	100 gpm 379 lpm	0.5% 1:200	1.0% 1:100	15 – 120 psi 1,03 – 8,3 bar	2" npt
A120 - 2% Twin (using 2 injectors for 1 solution)	114034	N/A	15 gpm 57 lpm	100 gpm 379 lpm	1.0% 1:100	2.0% 1:50	15 – 120 psi 1,03 – 8,3 bar	2" npt
DP20-2.3%	011390	NA	0.04 gpm 0,16 lpm	20 gpm 76 lpm	0.2% 1:500	2.3% 1:44	5.0 - 100 psi 0,34 – 6,9 bar	3/4" hose/1" npt 3/4" bsp/1" bsp
DP30-2.3%	011381	NA	0.25 gpm 0,95 lpm	30 gpm 114 lpm	0.2% 1:500	2.3% 1:44	5.0 - 100 psi 0,34 – 6,9 bar	3/4" hose/1" npt 3/4" bsp/1" bsp

- Parts for your A15 model may be reordered using the following parts list. Sketches are attached for your convenience in locating the correct part number.

**NOTE:** If you have trouble contacting your local distributor or do not know who your local distributor is, please call our Customer Service Department at (800) 344-6767 or (972) 245-9765, and someone will be happy to assist you.

**KITS AND PARTS LIST**  
**Advantage A15 – 4ml (npt = PN 113524, bsp = PN 113525)**

Description of Kit	Part #	Manual Reference
<b>Kit A – Wear Parts Kit</b> (dosage piston/shaft assy. and o-ring)	011851P	17, 51
<b>Kit C – Wear Parts Kit</b> (Kit A, inner cylinder and o-ring)	011854P	17, 51, 68, 81
<b>Kit D – Suction Tube Fitting Assy</b> (poppet, nut, washer, o-ring, spring, fitting)	011463	10, 11, 12, 13, 71, 80
<b>Kit E – Wear Parts Kit</b> (Kits C & D, inner cylinder (2 <sup>nd</sup> inner cylinder), shaft, pin and gasket)	011834P	7, 10, 11, 12, 13, 16, 17, 51, 64, 68, 71, 80, 81
<b>Kit F – Lower End Cylinder Kit</b> (inner & outer cylinder, ratio adjuster, o-rings, retainer clip, pin, gasket)	011960P	7, 16, 61, 64, 65, 66, 67, 68, 79, 81
<b>Kit G - Lower End Kit, complete</b> (Kit E, outer cylinder, ratio adjuster, o-rings, retainer clips, pins, retainer, filter, solution tube)	011843M	7, 10, 11, 12, 13, 16, 17, 25, 27, 51, 61, 64, 65, 66, 67, 68, 71, 79, 80, 81
<b>Kit H – Motor Piston Assy</b> (upper end kit, excluding knob)	011866	9
<b>Kit I1 – Inlet/Outlet Adapter Kit npt</b> (2 adapters, nuts & gaskets)	011054	16, 23, 24
<b>Kit I2 – Inlet/Outlet Adapter Kit bsp</b> (2 adapters, nuts & gaskets)	011054B	16, 23, 24
<b>Kit J1 – Remote/Side Injection Kit npt</b> (gasket, ¼" ID tube, adapters, nuts, female elbow connection, T connection, plugs, <i>without drilled body</i> )	011050	N/A
<b>Kit J2 – Remote/Side Injection Kit npt</b> (Kit J1 with body, drilled)	011051G	N/A
<b>Kit M – Mounting Bracket Kit</b> (mounting bracket, 4 hex caps & nuts)	011432	56, 57, 58

Manual Reference	Part #	Description of Part
1	194101E	Cover, gray
2	010002	Clamp-V
3	212003	O-ring, upper end body
7	194404P	Cylinder, inner
11	194417	Fitting, suction tube, ¼"
13	011453A	Poppet, check w/washer
15	194004	Seal retainer, o-ring
16	010016S	Gasket, inlet/outlet and cylinder
17	212005A	O-ring
20	212009B	O-ring, buna, at top, under bleeder
23	010023P	Nut, connector
24	010024N	Adapter, npt 1" x ¾"
24	010024A	Adapter, bsp 1" x ¾"
25	010025	Suction tube, ¼" x 4'
27	003067	Filter and foot valve, suction tube, ¼" ID
33	011155	<b>Poppet arm for upper assembly</b>
35	194116	Knob
40	194140E	Body, lower gray
51	011812	Shaft, Assy with dosage piston
61	194406P	Ratio adjustment sleeve
64	212017E	O-ring, inner cylinder, lower end
65	194310D	Pin, upper interlock
66	212025V	O-ring, outer cylinder, lower end
67	011919P	Cylinder, outer
68	011458	Cylinder, inner for #7
71	194414	Nut, suction tube fitting
79	194410SS	Pin, narrow interlock
80	194415	Twistlock
81	212516A	O-ring, inner cylinder (#68)

*Revised 5/18/01*



# ADVANTAGE A15-4ML REPAIR

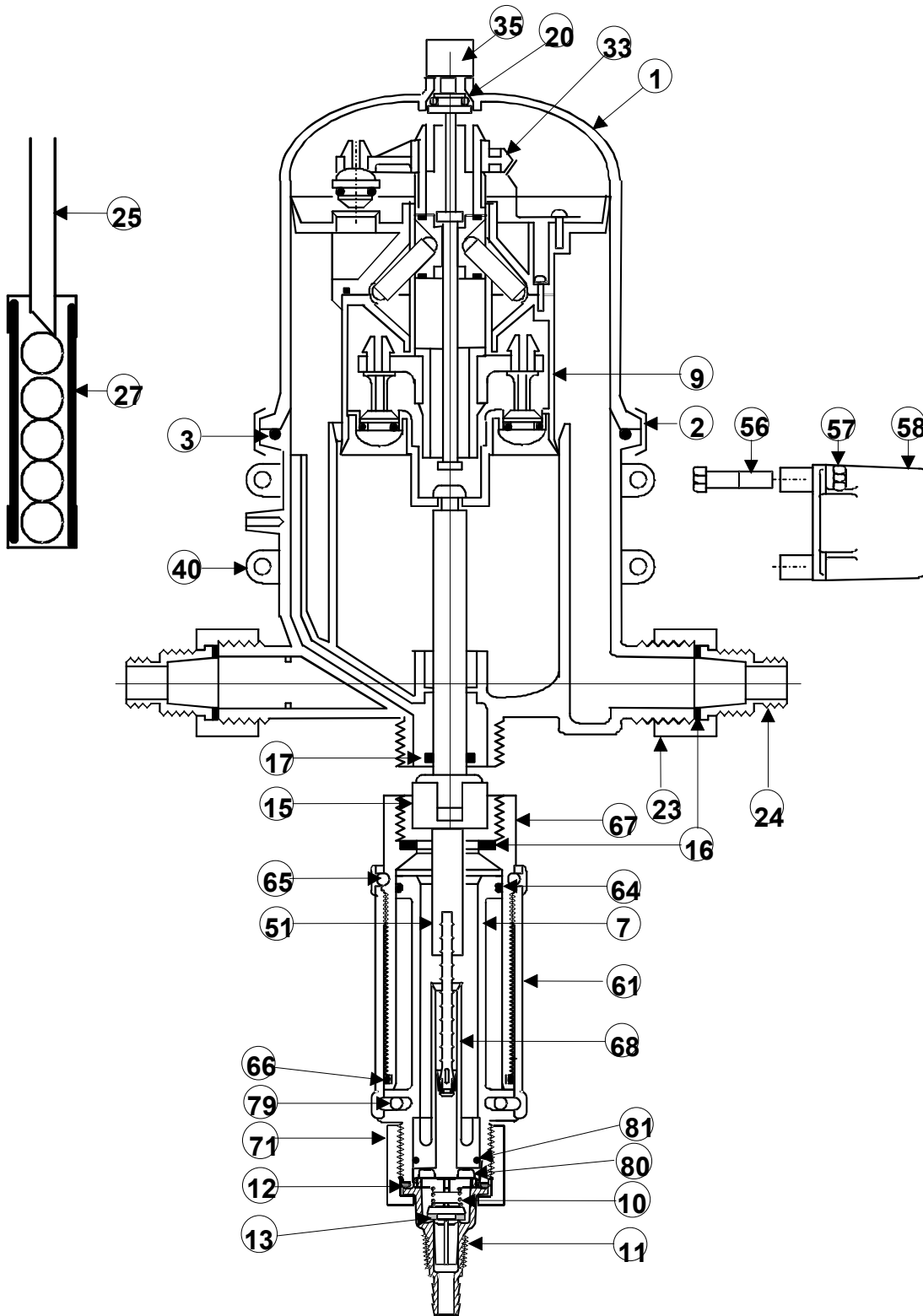

**KITS AND PARTS LIST**  
**Advantage A15 - 2.5% (npt = PN 113004, bsp = PN 113504P)**

Description of Kit	Part #	Manual Reference
<b>Kit A – Wear Parts Kit</b> (dosage piston and o-ring)	011850T	17, 44
<b>Kit B – Wear Parts Kit</b> (Kit A & shaft)	011945A	14, 17, 44, 51
<b>Kit C – Wear Parts Kit</b> (Kit A, inner cylinder and o-ring)	011850A	7, 17, 44, 64
<b>Kit D – Suction Tube Fitting Assy</b> (poppet, nut, washer, o-ring, spring, fitting)	011463	10, 11, 12, 13, 71, 80
<b>Kit E – Wear Parts Kit</b> (Kits C & D, shaft, pin and gasket)	011833P	7,10, 11, 12, 13, 16, 17, 44, 51, 64, 71, 80
<b>Kit F – Lower End Cylinder Kit</b> (inner & outer cylinder, ratio adjuster, o-rings, retainer clip, pin, gasket)	011961P	7, 16, 61, 64, 65, 66, 67, 79
<b>Kit G - Lower End Kit, complete</b> (Kit E, outer cylinder, ratio adjuster, o-rings, retainer clips, pins, retainer, filter, solution tube)	011843P	7, 10, 11, 12, 13, 14, 15, 16, 17, 25, 27, 44, 51,61, 64, 65, 66, 67, 71, 79, 80
<b>Kit H – Motor Piston Assy</b> (upper end kit, excluding knob)	011868	9
<b>Kit I1 – Inlet/Outlet Adapter Kit npt</b> (2 adapters, nuts & gaskets)	011054	16, 23, 24
<b>Kit I2 – Inlet/Outlet Adapter Kit bsp</b> (2 adapters, nuts & gaskets)	011054B	16, 23, 24
<b>Kit J1 – Remote/Side Injection Kit npt</b> (gasket, ¼" ID tube, adapters, nuts, female elbow connection, T connection, plugs, <i>without drilled body</i> )	011050	N/A
<b>Kit J2 – Remote/Side Injection Kit npt</b> (Kit J1 with body, drilled)	011051G	N/A
<b>Kit M – Mounting Bracket Kit</b> (mounting bracket, 4 hex caps & nuts)	011432	56, 57, 58

Manual Reference	Part #	Description of Part
1	194101E	Cover, gray
2	010002	Clamp-V
3	212003	O-ring, upper end body
7	194404P	Cylinder, inner
11	194417	Fitting, suction tube, ¼"
14 and 17	212005A	O-ring
15	194004	Seal retainer, o-ring
16	010016S	Gasket, inlet/outlet and cylinder
20	212009B	O-ring, buna, at top, under bleeder
23	010023P	Nut, connector
24	010024N	Adapter, npt 1" x ¾"
24	010024A	Adapter, bsp 1" x ¾"
25	010025	Suction tube, ¼" x 4'
27	011017	Filter, for suction tube, ¼" ID
33	011155	<b>Poppet arm for upper assembly</b>
35	194116	Knob
40	194140E	Body, lower gray
44	010044P	Dosage Piston
51	194301D	Shaft, with ears
61	194406P	Ratio adjustment sleeve
64	212017E	O-ring, inner cylinder, lower end
65	194310D	Pin, upper interlock
66	212025V	O-ring, outer cylinder, lower end
67	194407P	Cylinder, outer
71	194414	Nut, suction tube fitting
79	194410SS	Pin, narrow interlock
80	194415	Twistlock

*Revised 3/26/01*

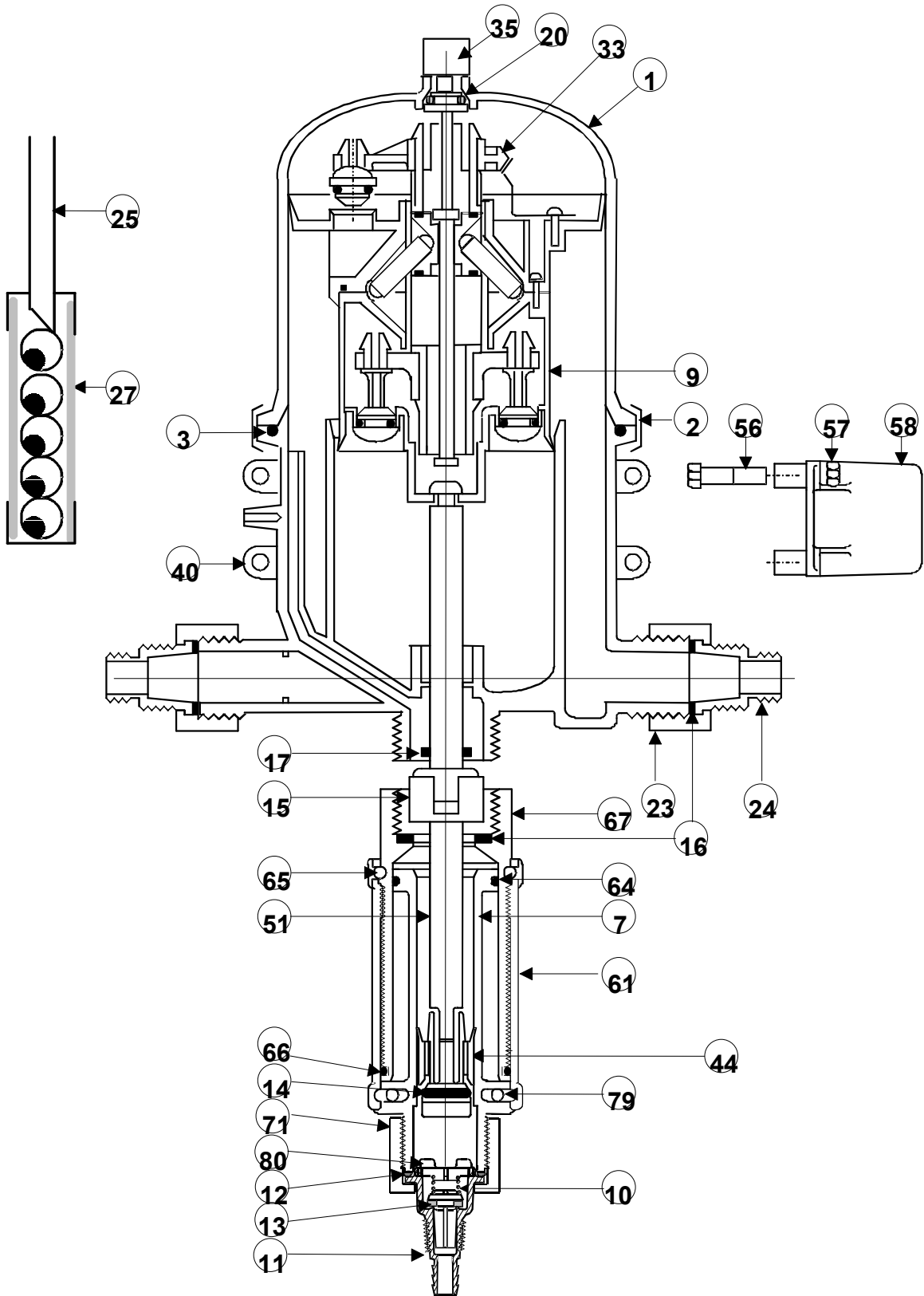

A15-2.5%



DOSMATIC U.S.A., INC.  
1230 Crowley Circle • Carrollton, Texas 75006 U.S.A.  
Phone: (972) 245-9765 • Fax: (972) 245-9000  
www.dosmatic.com

**RETURN AUTHORIZATION FORM**

RA Number: \_ \_ \_ \_ \_

**Above Section for Dosmatic Use Only**

**Please fill out and return with the unit, along with original invoice**

**NOTE: For faster service, please write RA Number on outside of return box**

Contact Name: \_\_\_\_\_

Company Name: \_\_\_\_\_

Phone Number: \_\_\_\_\_ Fax Number: \_\_\_\_\_

Serial Number: \_\_\_\_\_ Model: \_\_\_\_\_

Reason for Return:  Repair  Replacement  Other

Details of reason for return \_\_\_\_\_

**To what address should Dosmatic ship your repaired or replacement unit?:**

\_\_\_\_\_  
\_\_\_\_\_  
\_\_\_\_\_

Payment Method:  Check  COD  Direct Bill (Distributor Only)

MasterCard  Visa Credit Card Number: \_\_\_\_\_

Name on Card: \_\_\_\_\_ Expiration Date: \_\_\_\_\_

Card Billing  
Address: \_\_\_\_\_

**NOTE: There will be a 20% restocking fee for items accepted for credit; items to be returned to seller's plant (subject to inspection), transportation prepaid.**

**Return to:** Dosmatic U.S.A., Inc. • 1230 Crowley Circle • Carrollton, TX 75006

# The Dosmatic Warranty

We believe that we make the best and most reliable water-driven injectors available. Therefore, our warranty reflects our confidence; we will back our units with the best guarantee available.

1. Dosmatic will provide for replacement of all parts proven to be defective in material or workmanship from the date of purchase for the following time periods:

## In the United States and Canada

3 years – The cover and body  
2 years – The motor piston  
1 year – The lower end\*

## All Other

1 year – Cover, body, motor piston, lower end\*

**\*NOTE:** (Your only responsibility is ordinary maintenance – filtering incoming water and solution and replacing the o-ring and dosage piston when worn)

2. Return the unit to the distributor or to Dosmatic's manufacturing facility, freight prepaid. Upon inspection, the unit will be repaired or replaced, at Dosmatic's option, free of charge, if found to be defective in material or workmanship and will be returned freight prepaid.
3. This warranty is invalid if the defects are found to be due to the product's misuse, lack of maintenance, defective installation, freezing, water hammer, misuse or abuse or unwanted side effects due to the chemicals you choose to inject. The dosage piston, seals and o-rings are not covered under warranty nor is damage caused by water impurities, including but not limited to, sand or iron. A filter no coarser than 140 mesh or 104 micron must be used in front of the unit for the warranty to be valid. Dosmatic will not be responsible if the unit is used under conditions outside of its operating tolerances listed in this manual.
4. Dosmatic shall not be liable for incidental or consequential damage, such as any economic loss, resulting from breach of this written warranty or any implied warranty.
5. To return a unit for repair:
  1. **Thoroughly rinse** all chemical solution from the lower end of the unit.
  2. **Drain the water** from the upper end of the injector, leaving a small amount so that the seals do not dry out.
  3. If possible, identify the chemical solution injected and include a copy of the chemical manufacturer's Material Safety Data Sheet for each chemical injected.
  4. All claims for warranty repair must include a copy of the original invoice listing the serial number of the injector to be repaired.
  5. With each injector returned, please fill out the return form in this manual.
  6. If returning to Dosmatic, ship to:

Dosmatic U.S.A.  
1230 Crowley Circle  
Carrollton, TX 75006
7. For the name of your nearest Service Center, call us toll free at (800) 344-6767 or at (972) 245-9765.
6. There are no warranties which extend beyond those described above.

## SPECIFICATIONS

### ALL A15 MODELS

DESCRIPTION	USA	METRIC
<b>FLOW RATE:</b> <b>MINIMUM</b> <b>MAXIMUM</b>	0.04 gpm (2.4 gph) 15 gpm (900 gph)	0,15 lpm (9,1 lph) 57 lpm (3,4 m <sup>3</sup> /h)
<b>PSI/BAR:</b> <b>MINIMUM</b> <b>MAXIMUM</b>	4 psi 85 psi	0,27 bar 6,0 bar
<b>INLET/OUTLET</b> <b>PIPE CONNECTION</b>	¾" hose & 1" npt	¾" bsp & 1" bsp
<b>MAXIMUM TEMPERATURE</b>	100° F	38° C
<b>SHIPPING CARTON SIZE</b> <b>SINGLE</b> <b>MASTER (6 Single)</b>	23" X 8" X 9" 25" x 18" x 24"	58,5 X 20,3 X 22,9 cm 63,5 x 45,7 x 61 cm

MODEL	SYSTEM	FEED RATIOS MINIMUM	FEED RATIOS MAXIMUM	SUCTION HOSE SIZE
<b>A15 – 4ML</b>	USA	0.025% or 1:4000	0.4% or 1:250	¼" ID
	METRIC	0.025% or 1:4000	0.4% or 1:250	6,4 mm ID
<b>A15 – 2.5%</b>	USA	0.2% or 1:500	2.5% or 1:40	¼" ID
	METRIC	0.2% or 1:500	2.5% or 1:40	6,4 mm ID

#### DECLARATION OF COMPLIANCE WITH “CE” DIRECTIVE – “MACHINES”

Dosmatic U.S.A./International, Inc. declares that the equipment described hereafter: Proportional, non-electric injectors Models A15 – 4ml and 2.5% are in conformity with the directive “machines” 89/392/CEE dated 14, June 1989, modified by directive 93/68/CEE dated July 22, 1997.

**Dosmatic U.S.A./International, Inc.**  
**1230 Crowley Circle•Carrollton, TX 75006**  
**Tel: (972) 245-9765**  
**Fax: (972) 245-9000**  
**Toll Free: (800) 344-6767**  
**E- mail: [info@dosmatic.com](mailto:info@dosmatic.com)**  
**Web site: [www.dosmatic.com](http://www.dosmatic.com)**

**Dosmatic Europe**  
**Lerenveld 14•Lint B-2547**  
**BELGIUM**  
**Tel: (32) 3 488 73 71**  
**Fax: (32) 3 480 02 27**  
**E-mail: [info@dosmatic-europe.com](mailto:info@dosmatic-europe.com)**

**PN 013503                      7/26/01**

U.S. patents 4,558,715 and 5,137,435 – European , Japanese, Canadian patents pending

T:marketing/manuals/installmanuals/current manuals/A15-PN013503

