



**NOVA CONTROLS**  
LEADING THE WAY  
A **Hydro** Systems Company

# Flush Manifold

FOR LIQUID LAUNDRY SUPPLY SYSTEMS

---

---

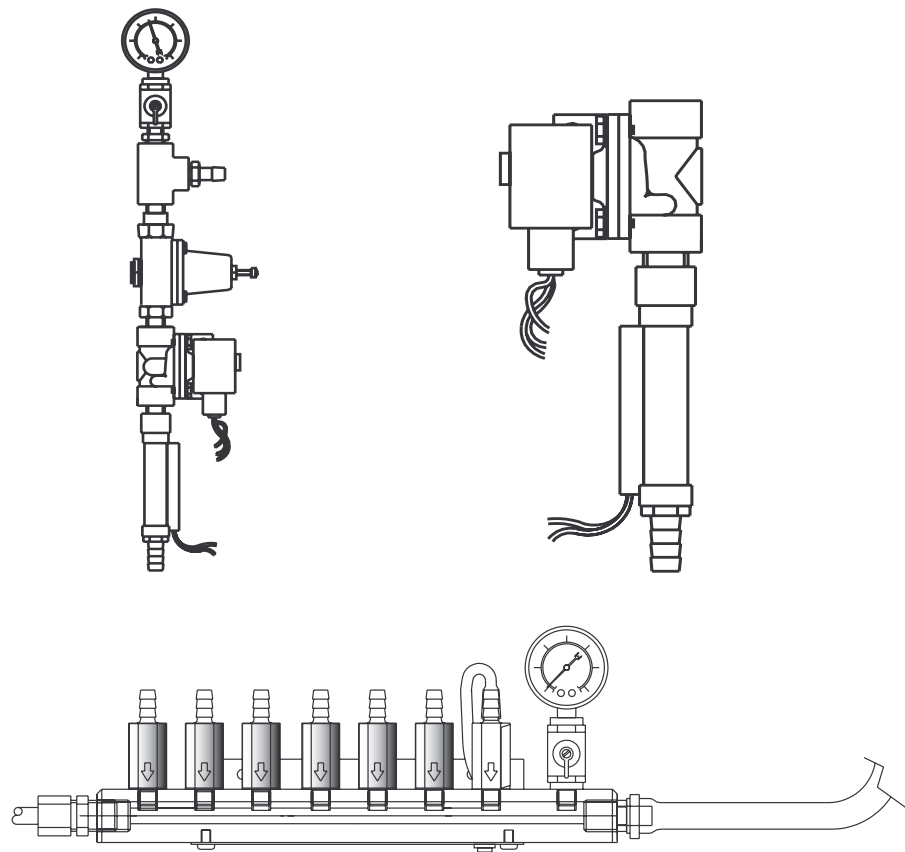

## Reference Manual

FM-500 Series

---

---

**Figure 1.0.a Description, Standard Flush Valve**

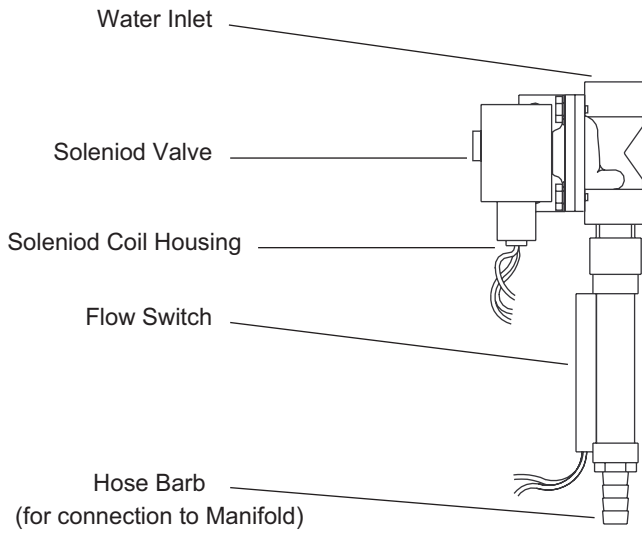

**Figure 1.0.b Description, Industrial Flush Valve**

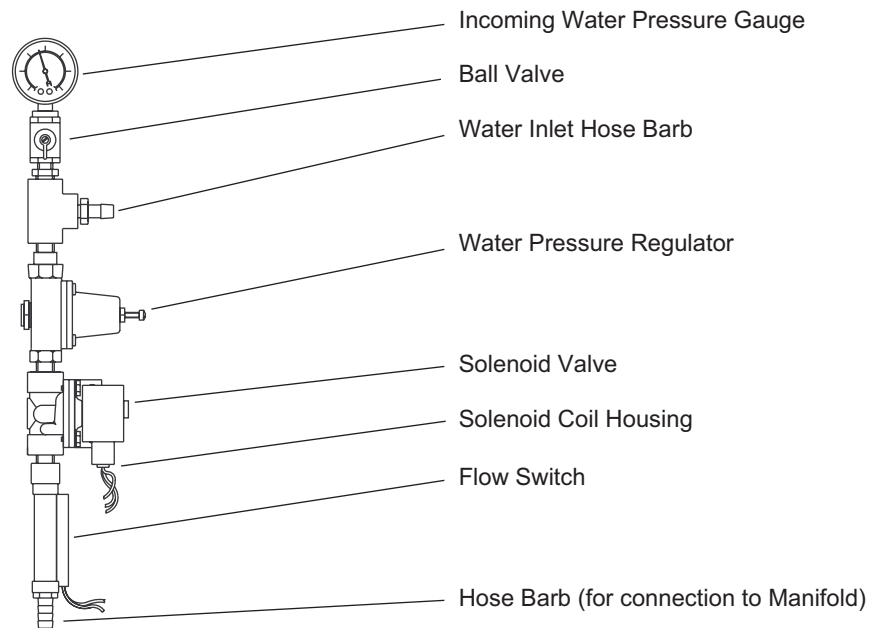

## 1.0 DESCRIPTION

DESCRIPTION

The FM-500 series Flush Manifold is a universal design compatible with our LM and LL series liquid laundry dispensing systems.

INSTALLATION

The FM-500 series Flush Manifold is comprised of two major components, a Manifold Assembly and a choice of two different Flush Valve assemblies.

**The Standard Flush Valve Assembly** consists of a 1/2" FPT water inlet at the top of a brass solenoid valve, a flow switch, and a 1/2" hose barb at the bottom for hose connection to the Manifold Assembly.

SYSTEM SETUP

**The Industrial Flush Valve Assembly** consists of a single water inlet (1/2" hose barb and 1/2" tee assembly), a water pressure gauge with an "open to read" water valve, a water pressure regulator, a brass solenoid valve, and a flow switch with a 1/2" hose barb at the bottom for hose connection to the Manifold Assembly.

SPARE PARTS LISTING

The **Manifold Assembly** is a CPVC pipe assembly with check valves, a vacuum relief valve, and a pressure gauge with an "open to read" ball valve. A 1/2" hose barb for hose connection to the Flush Valve Assembly is on one end and a 5/8" tube compression fitting for polyflow discharge tubing connection is on the other end.

SPECIFICATIONS

The modular design allows more installation flexibility with liquid laundry chemical dispensing systems. Both the Manifold and Valve Assembly Brackets may be reversed to allow installation for flow from left to right.

### 1.1 Theory of Operation

The FM-500 series Flush Manifold transfers liquid laundry chemical products from the dispensing system to the washer using water flow (or flush) via a single discharge tube. The dispenser pumps the chemical products into the manifold via the check valves. The flush valve controls water flow through the manifold, which in turn transfers product to the washer. The vacuum relief valve allows pressure within the manifold body to equalize without drawing a siphon on the product pumps. A manifold pressure gauge measures system pressure while flushing. The flush valve may be controlled by any of the following:

- An Orion LL-6000 with an EXF Orion controller
- An LM-100 with an Orion II PI board and an EXF Orion controller
- An 8-pump PI board and an EXF Orion controller

Figure 1.0.c Description, Manifold

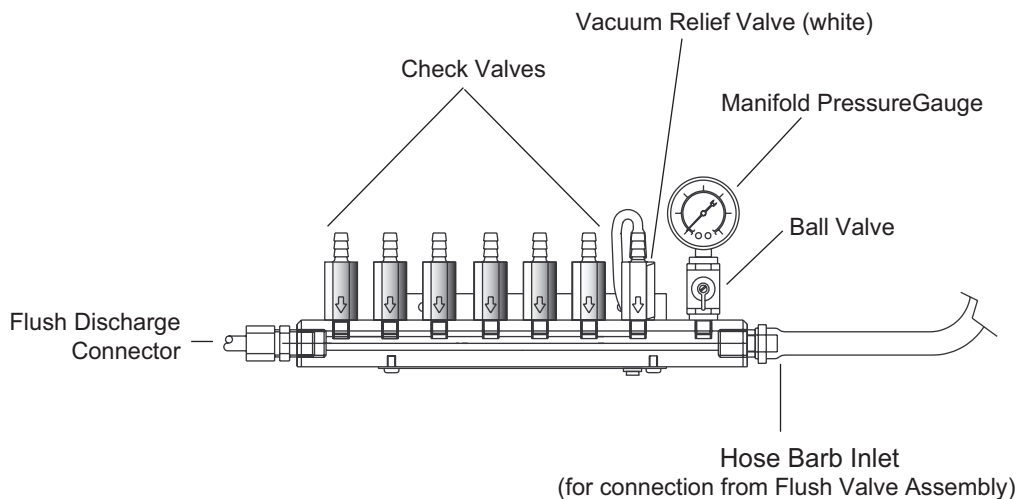

## 2.0 INSTALLATION

DESCRIPTION

INSTALLATION

The laundry dispensing system should be installed prior to the Flush Manifold. A method of driving the flush valve needs to be determined on the initial site survey. We strongly recommend using the flush valve drive capabilities of our Orion EXF controllers, with our safety interlocks in place for the most reliable, and safest, operation.

SYSTEM SETUP

**CAUTION:** A locally approved backflow prevention device—not provided—is required for safe and legal operation. A water pressure regulator is required for use with our standard Flush Valve Assembly. This regulator may be shared by a number of flush valves, limited by the water flow and pressure at the site.

SPARE PARTS LISTING

### 2.1 Manifold Assembly Installation

2.1.1 Position the Manifold Assembly on the wall below the dispenser Pump Module. Reverse the Manifold mounting bracket position when flow from left to right is desired.

**NOTE:** Allow clearance for the Orion LM-100 Pump Module cabinets to open.

2.1.2 Using a pencil, outline each of the two holes on the Manifold mounting bracket.

2.1.3 Drill the outlined holes with a 1/4" bit and place a wall anchor (provided) in each hole.

2.1.4 Secure the Manifold assembly to the wall anchors with supplied screws.

SPECIFICATIONS

### 2.2 Pump Tube Connection

Use short lengths of 3/8" ID tubing and appropriate size (3/8" x 3/8" or 5/16" x 3/8") hose barbs (supplied in the installation kit) to connect the discharge side of the dispenser pumps to the Check Valve hose barbs.

2.2.1 Connect lengths of the 3/8" ID flexible tubing that are long enough to connect the dispenser pump tubes with the corresponding check valves on the flush manifold. Secure the flexible tubing to the pump tube barbed fitting with hose clamps or tie wraps to ensure a leak free assembly.

2.2.2 Trim the 3/8" ID tubes to fit—do not connect to the check valves yet.

2.2.3 Perform “Calibrate Pumps” on the Orion controller, capturing product at the open ends of the flexible tubing.

2.2.4 Connect flexible tubing to the hose barbs on the check valves. Secure with hose clamps or tie wraps to ensure a leak free assembly.

### 2.3 Flush Valve Installation

2.3.1 Position the Flush Valve Assembly on the wall beside the dispenser Pump Module. Reverse the Flush Valve mounting bracket position when flow from left to right is desired.

2.3.2 Using a pencil, outline each of the two holes on the flush valve assembly mounting bracket.

2.3.3 Drill the outlined holes with a 1/4" bit and place a wall anchor (supplied) into each hole.

2.3.4 Secure the flush valve assembly to the wall anchors with supplied screws.

### 2.4 Water Supply Connection, Standard Flush Valve

Use approved pipe with a minimum 1/2" ID for water supply connection from the water pressure regulator and back flow prevention device—not provided.

**NOTE:** Always use an approved Back Flow Prevention Device and Water Pressure Regulator. Plastic fittings can be replaced with fittings required by local plumbing codes.

2.4.1 Measure the distance from the water pressure regulator (not provided) to the Flush Manifold water supply connection.

2.4.2 Cut a length of 1/2" ID pipe (not provided) to the desired length.

2.4.3 Connect one end of the pipe to the output of the water pressure regulator and the opposite end to the water inlet on the flush valve assembly.

2.4.4 Affix provided plumbing caution label in area of Flush System.

## 2.5 Water Supply Connection, Industrial Flush Valve

Use 1/2" ID pipe for water supply connection from the back flow prevention device (not provided).

**WARNING:** An approved Back Flow Prevention Device **MUST** be used between the Flush Valve and water source.

2.5.1 Measure the distance from the water source to the Flush Valve water supply connection.

2.5.2 Cut a length of 1/2" ID pipe (not provided) to the desired length.

2.5.3 Connect one end of the pipe to the water source and connect the opposite end to the water inlet hose barb.

2.5.4 Affix provided plumbing caution label in area of Flush System.

## 2.6 Flush Discharge Connection

Use a single 5/8" polyflow flush outlet tube (not provided) to deliver product to the laundry machine.

**CAUTION:** The flush discharge tubing **SHOULD NOT** exceed 50'.

2.6.1 Measure the distance from the Flush Manifold to the laundry machine.

2.6.2 Cut a length of 5/8" polyflow tubing (not provided) to the desired length.

2.6.3 Connect the tubing to the Flush Manifold discharge 5/8" compression fitting.

2.6.4 Route the tubing to the laundry machine and secure at the product injection port.

**NOTE:** Secure the flush discharge tube at the laundry machine so that the water flush will rinse the product injection area. This will help ensure against chemical damage to the laundry machine. Secure all tubing for a neat and clean installation.

## 2.7 Flush Valve to Manifold Connection

2.7.1 Measure distance from Flush Valve to the Manifold and trim the provided 1/2" ID Hose to fit.

2.7.2 Connect the hose to the hose barb on the Flush Valve Assembly and the hose barb on the inlet side of the Manifold.

2.7.3 Secure both ends of the hose with provided ratchet clamps.

## 2.8 Electrical Connections

The FM-500 series flush valve may be equipped with a choice of AC voltage solenoid coils for flush activation. Confirm that your coil voltage is correct for your application. LM-100 series and LL-6000 series dispensers (with an Orion II PI board or an 8-pump PI board) utilize 24VAC output for the flush valve.

**WARNING:** DO NOT connect any voltage other than what is called out on the solenoid coil. A wire conduit is required for solenoid coil wiring when using any coil voltage over 24 VAC. The solenoid coil housing is threaded to accommodate the conduit.

The solenoid valve has two wires, labeled "Solenoid Coil," with 1/4" female push-on connectors for connection to the dispenser's flush output wiring. A green/yellow ground wire is also present and should be run to the dispenser cabinet.

The flow switch has two wires, labeled "Flow Switch," with a 1/4" male and a 1/4" female push-on connector. These wires connect to the dispenser's flow switch input on the circuit board or to the white wires on our Flush Wiring Harness. These wires are low voltage and may be run exposed in most areas.

2.8.1 Connect the solenoid coil power wires to the Solenoid coil wires from the dispenser's PI board, or to the solenoid coil wires on the Flush Wiring Harness.

2.8.2 Connect the Flow Switch wires to the Flow Switch input on the dispenser's PI board, or to the flow switch wires on the Flush Wiring Harness.

DESCRIPTION

INSTALLATION

SYSTEM SETUP

SPARE PARTS LISTING

SPECIFICATIONS

### 3.0 SYSTEM SETUP

DESCRIPTION

INSTALLATION

SYSTEM SETUP

SPARE PARTS LISTING

SPECIFICATIONS

Check entire dispensing system for correct electrical and plumbing connections. After pump calibration and formula programming, test run the system to determine appropriate flush time setting to transfer all product to the washer. Input new flush time in program mode of the controller. Also, reconfirm that the washer calls for product at appropriate times and that the dispensing system pumps when it should. Flush system pressures should be measured at the manifold pressure gauge by opening the gauge protection ball valve while flushing. Adjust the water pressure regulator for no more than a 10 psi reading on the manifold gauge while flushing. Inspect the flush system for water leaks. Test run a load of linen.

**CAUTION:** Turn off gauge valve when you have finished reading the manifold pressure to prevent water hammer damage to the gauge.

**NOTE:** To manually open flush valve in order to purge or clean water lines and manifold, press the Up or Down arrow on the Orion EXF controller to access a manual flush control.

**OPERATING WARNING:** Never mix incompatible chemicals in the flush manifold. Mixing chemicals can cause personal injury or mechanical damage to the unit.

### 4.0 SPARE PARTS LISTING

**Figure 4.0.a**  
**Industrial Flush Valve**

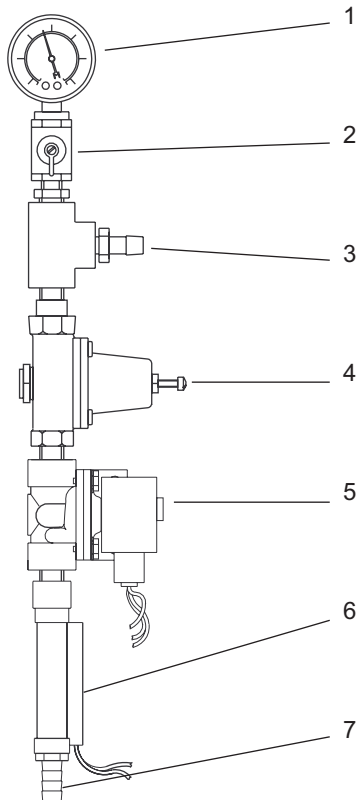

**Figure 4.0.b**  
**Standard Flush Valve**

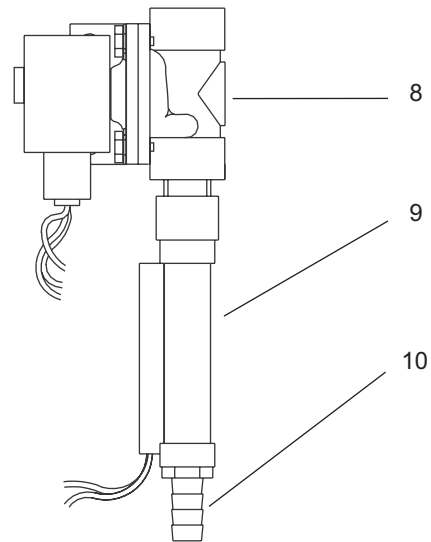

**Figure 4.0.c Flush Manifold**

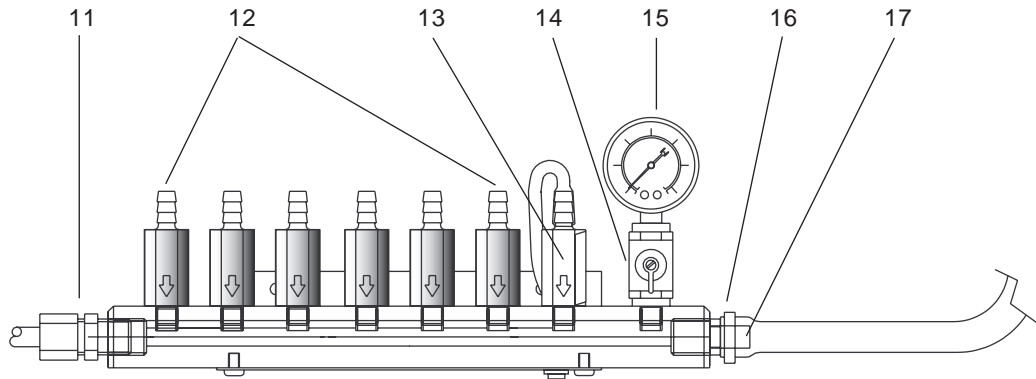

DESCRIPTION

INSTALLATION

SYSTEM SETUP

SPARE PARTS LISTING

SPECIFICATIONS

**Ordering Information**

A manifold and choice of flush valves need to be ordered together to make up an FM-500 series flush system. Manifolds may be configured with between 3 - 8 pumps. Specify number of pumps when ordering.

**NOTE: Specify "Metric" when ordering if metric equivalent plumbing fittings are desired.**

**ITEM DESCRIPTION**

**PART NUMBER**

<b>Industrial Flush Valve, Specify Coil Voltage .....</b>	<b>00-04816-xx</b>
1 Pressure Gauge .....	49-04796-00
2 Valve, Ball, 1/4" Male/Female .....	41-04797-00
3 Hose Barb, 1/2" Tube .....	41-04469-00
4 Pressure Regulator .....	49-04802-00
5 Solenoid Valve, Specify Coil Voltage .....	49-04803-xx
6 Flow Switch .....	56-04470-00
7 1/2" Hose Barb Fitting, For Flow Switch .....	41-04478-00
<b>Standard Flush Valve, Specify Coil Voltage .....</b>	<b>00-04815-xx</b>
8 Solenoid Valve, Specify Coil Voltage .....	49-04803-xx
9 Flow Switch .....	56-04470-00
10 1/2" Hose Barb Fitting, For Flow Switch .....	41-04478-00
<b>Flush Manifold, 3 to 8 Pumps Avail., Specify # of Pumps (-03, -04, -05, -06, -07, -08) .....</b>	<b>00-04795-0x</b>
11 5/8" Flush Discharge Compression Fitting .....	41-03561-1081
12 Check Valve, 3/8" Hose Barb .....	41-04207-46
13 Vacuum Relief Valve (White) .....	41-04807-00
14 Valve, Ball, 1/4" Male/Female .....	41-04797-00
15 Pressure Gauge .....	49-04808-00
16 Ratchet Clamp .....	41-04474-00
17 1/2" Hose Barb .....	41-04469-00
<b>Flush Valve Mounting Kit (screws &amp; wall anchors) .....</b>	<b>13-04814-00</b>
<b>Manifold Accy. Kit, 3 to 8 Pump Kits Avail., Specify # of Pumps (-03, -04, -05, -06, -07, -08) .....</b>	<b>13-04794-0x</b>
1/2" ID Braided Poly Tubing, 3 feet .....	03-04471-036
3/8" ID EVA Tubing .....	41-04812-00
Hose Barb, 5/16" x 3/8" .....	41-05112-00
Hose Barb, 3/8" X 3/8" .....	37-07157-0606
1/4" Male Polypro Hole Plug (to plug vacant check valve hole) .....	41-04468-00
<b>Orion EXF Controller (Specify SAE or Metric) .....</b>	<b>01-04750-03</b>

## 5.0 SPECIFICATIONS FM-500 SERIES

DESCRIPTION

INSTALLATION

SYSTEM SETUP

SPARE PARTS LISTING

SPECIFICATIONS

### 5.1 Unit Specifications

Size, Manifold, 6 position: ..... 17" wide X 6.25" high X 2.5" deep (43.2cm. W X 15.9cm. H X 6.4cm. D)  
Size, Solenoid Assembly: ..... 6.25" wide X 10.25" high X 3.0" deep (15.9cm. W X 26.0cm. H X 7.6cm. D)  
Weight, Manifold Assembly: ..... 2.5 lbs. (1.1 kg.)  
Weight, Solenoid Assembly: ..... 2.1 lbs. (0.9 kg.)  
Power (Specify Coil Voltage): .... 24, 110, 208, 240 volts AC, 50 or 60 hertz

#### 5.1.a Water Specifications

Maximum Pressure: ..... No more than 10 PSI at manifold gauge, when flushing.  
Maximum Temperature: ..... 120° F (48.9° C)  
Minimum Temperature: ..... 40° F (4.4° C)

**NOTE:** All specifications subject to change without notice.

### 5.2 Ordering Information

See *Section 4.0–Spare Parts Listing*, to order manifold, choice of flush valve and/or replacement parts.

### 5.3 Limited Warranty

SELLER warrants solely to BUYER the Products will be free from defects in material and workmanship under normal use and service for a period of one year from the date of completion of manufacture. This limited warranty does not apply to (a) hoses; (b) and products that have a normal life shorter than one year; or (c) failure in performance or damage caused by chemicals, abrasive materials, corrosion, lightning, improper voltage supply, physical abuse, mishandling or misapplication. In the event the Products are altered or repaired by BUYER without SELLER'S prior written approval, all warranties will be void.

NO OTHER WARRANTY, ORAL, EXPRESS OR IMPLIED, INCLUDING ANY WARRANTY OF MERCHANTABILITY OR FITNESS FOR ANY PARTICULAR PURPOSE, IS MADE FOR THESE PRODUCTS, AND ALL OTHER WARRANTIES ARE HEREBY EXPRESSLY EXCLUDED.

SELLER'S sole obligation under this warranty will be, at SELLER'S option, to repair or replace F.O.B. SELLER'S facility in Watsonville, California any Products found to be other than as warranted.

### 5.4 Limitation of Liability

Seller's warranty obligations and buyers remedies are solely and exclusively as stated herein. Seller shall have no other liability, direct or indirect, of any kind, including liability for special, incidental, or consequential damages or for any other claims for damage or loss resulting from any cause whatsoever, whether based on negligence, strict liability, breach of contract or breach of warranty.



**NOVA** CONTROLS  
LEADING THE WAY

A **Hydro** Systems Company

225 WESTRIDGE DRIVE  
WATSONVILLE  
CALIFORNIA  
95076-4168 U.S.A.

TEL 831.786.1470  
FAX 831.786.1650